

## **G17 GROSS BAGGING SCALE**

The Don Marshall Company, Inc.  
235 Maple Street - PO Box 124  
Plain City, Ohio 43064  
614-873-8520, Fax: 614-873-8338  
[info@donmarshall.net](mailto:info@donmarshall.net)

# INSTRUCTIONS AND PARTS LIST FOR THE HOWE RICHARDSON G17 GROSS BAGGING SCALE

## — TABLE OF CONTENTS —

|   | Page |
|---|------|
| APPLICATION . . . . .   | 1    |
| DESCRIPTION . . . . .   | 1    |
| PLANNING BEFORE INSTALLATION . . . . .                        | 1    |
| INSTALLATION . . . . .  | 1    |
| PROCEDURE BEFORE OPERATION . . . . .                          | 2    |
| Preliminary Adjustments . . . . .                             | 2    |
| Middle Bearing Brackets . . . . .                             | 2    |
| Vertical Beam Movement . . . . .                              | 2    |
| Trigger Sensitivity . . . . .                                 | 2    |
| OPERATION . . . . .   | 2    |
| Regulating The Feed Rate . . . . .                            | 2    |
| Power Feeder . . . . .  | 3    |
| Compensation . . . . .  | 3    |
| Balancing Scale Empty . . . . .                               | 3    |
| Balancing The Bag . . . . .                                   | 4    |
| COMPONENTS . . . . .  | 4    |
| Bagholder . . . . .   | 4    |
| Quick Change Bag Spout . . . . .                              | 4    |
| Dash Pot . . . . .  | 4    |
| Sway Control Link . . . . .                                   | 4    |
| Counter . . . . .   | 4    |
| Air Vent . . . . .  | 4    |
| MAINTENANCE . . . . .   | 4    |
| Zero Position & Range . . . . .                               | 4    |
| Zero Position Adjustment . . . . .                            | 4    |
| Range Adjustment . . . . .                                    | 4    |
| Torsion Rod Adjust Bolt . . . . .                             | 5    |
| Compensation Spring . . . . .                                 | 5    |
| Bag Clamp Adjust Bolts . . . . .                              | 5    |
| Cleaning . . . . .  | 5    |
| Lubrication . . . . .   | 5    |
| Dash Pot . . . . .  | 5    |
| Gate Bearing . . . . .  | 5    |
| Chart . . . . .   | 5    |
| HOW TO USE THE PARTS LIST . . . . .                           | 6    |
| PARTS LIST & FIGURES 1, 2, 3 & 4 . . . . .                    | 7-10 |
| DASH POT (600047-01) . . . . .                                | 11   |
| REFERENCE DRAWINGS: . . . . .                                 |      |
| G17 Outline Arrangement (Octagonal Spout) No. 48001 . . . . . | 12   |
| G17 Outline Arrangement (Square Spout) No. 41450 . . . . .    | 13   |

**MODELS:**  
600048-10  
600049-09  
601347-08  
601348-08

# INSTRUCTIONS AND PARTS LIST FOR THE HOWE RICHARDSON G17 GROSS BAGGING SCALE

## APPLICATION

The "G17" was created as a simple low-headroom scale for weighing into open-mouth paper and textile bags. It will weigh materials fed by gravity from an overhead bin, or can be supplied with a Howe Richardson Model "E10" Belt Feeder for lumpy and non-free flowing materials. It may also find application with other types of power feeders furnished by Howe Richardson Scale Company or by the user.

## DESCRIPTION

The "G17" Gross Bagging Scale consists of the following basic parts: the inlet chute, feed gate and regulating slide housed in a sheet metal frame of welded construction. The bag spout and bag-holder hang from one end of the beam and the balance box and weigh weights from the other end. The balance indicator is located at the front of the scale. The feed gate and regulating slide handles are readily accessible. The feed gate triggering mechanism is mounted on the right hand side of the machine.

## PLANNING BEFORE INSTALLATION

The installation should be planned carefully to get maximum benefit from the unit. It is most important that it be mounted at a convenient height from the floor to accommodate the longest bag in use. If a bag conveyor and sewing machine are included in the installation, make allowance for these units beneath the scale. Provide as much clearance as possible to enable the operator to perform his work effectively.

We recommend that you build a cutoff slide and an access door in the supply bin close to the top of the scale-housing (or just above the feeder inlet if a feeder is used).

The stream of material to the scale must be uniform if scale accuracy is to be kept within acceptable limits. Good design of the feeding arrangement is necessary to maintain constant weighings. Having at least two full weighings in the supply bin above the scale will help to keep the feed stream uniform. We recommend the installation of a bin level switch in the supply bin to maintain this required minimum.

## INSTALLATION

The "G17" is shipped in one carton. After unpacking and removing all parts, refer to the Outline Arrangement drawing and figures herewith and proceed as follows:

1. Remove the large shipping plate that covered the scale during shipment. Replace the bolts that held it in place but do not tighten them.
2. Bring the scale into position and fasten it in place by sliding the mounting bars 109\* over the bottom flange on the supply bin or feeder and then tightening down the bolts. Be sure the scale is level. If the installation includes an "E10" feeder, an L-shaped bracket will be supplied; mount this on top of the scale and bolt it to the feeder.
3. Power-fed scales only: mount the limit switch on the side of the scale housing as shown in figure 2. See that the limit switch arm is not forced beyond its normal limit of travel. If adjustment is required, loosen the switch arm, rotate it as necessary, then tighten.
4. Remove all wire blocks, grease, etc., that were used in shipping. Hang the balance box assembly, 413, 414, 415 and 416 (without weigh weights) from the end of the weigh beam. Now loosen the two lock bolts (on both sides of the spout) and slide the two protective clips, 115, all the way down until they clear the housing by at least 1/8" when the beam is on its bottom stop. These clips protect the beam pivots in shipment by holding the beam firmly against its upper stop. Re-tighten the lock bolts.
5. The dashpot oil was removed before shipment and packed separately in a bottle. Replace in accordance with the dashpot instructions on page 11.
6. With the main beam level, the indicator pointer should point to the balance line on the indicator plate. If it does not, see zero adjustment procedure on page 4.

The scale should now be completely assembled. Make sure that the pivots are resting in the V-shaped steelings, 420A and 421A. **DO NOT REMOVE OR LOOSEN THESE PIVOTS.** To do so would alter the beam ratio and result in false weighings. See that push rod 408 is assembled and bolted to beam. Check carefully to see that the beam, pointer, and handles 304 and 306 move freely and do not foul any part of the structure. See that all locknuts are tight and all cotter pins open. On scales with camgrip bagholder, the bagholder release bar can be located to the left instead of to the right if desired. To make the change, remove the four bagholder mounting bolts and rotate the bagholder assembly 180°. Replace the mounting bolts and tighten them securely.

\*The first digit in the mark numbers used in the text denotes its figure number: i.e., 109 - Figure 1 - Mark 9

assembly 180°. Replace the mounting bolts and tighten them securely.

## PROCEDURE BEFORE OPERATION

**PRELIMINARY ADJUSTMENTS:** Before putting the scale into operation, check the following settings to make sure that they were not disturbed in shipment. Those adjustments not likely to require attention before the scale is operated are discussed in the maintenance section.

**MIDDLE BEARING BRACKETS:** It should be possible to move the main beam sideways in the middle bearing brackets. This movement should be from 1/32" to 1/16". If necessary, the middle bearing brackets can be shimmed slightly to obtain this clearance. It should be possible to move the bag spout sideways on the end pivots; this movement also should be approximately 1/32" to 1/16". If necessary, the spout suspension shackles 421-C may be shifted to obtain the correct movement. The above adjustments are completed at the factory, and should not under normal conditions require field adjustment.

**VERTICAL BEAM MOVEMENT:** There should be approximately 3/8" between the beam stop bolt and the top of the beam when the beam is level. If necessary, loosen the locknut on the beam stop bolt and turn the beam stop bolt up or down. Tighten the locknut. The total beam movement must allow the pointer to sweep the entire scale on the indicator plate. See figures 1 and 4.

**TRIGGER SENSITIVITY:** Refer to the section entitled "Balancing Scale Empty" under "Operation". After balancing the scale empty, and making sure that the material supply is shut off, proceed as follows:

1. Pull down on feed gate handle, thus opening the feed gate. This motion should engage trigger knife edge 209 and bearing 205A. With the feed gate open, trigger trip screw 205D should just touch the beam without pushing the indicator pointer off zero. If necessary, adjust the trigger trip screw to suit.
2. Carefully hang 20 ounces (1 lb. 4 ozs.) of weight on the bag spout. The feed gate should remain open. If the trigger trips and the feed gate closes, turn the trigger trip screw (Figure 2, mark 205D) clockwise until the trigger no longer trips.

Place an additional 2 ounces (Total of 1 lb.

6 ozs.) on the bag spout. The trigger should trip and the feed gate close. If the trigger does not trip, correct by turning the trigger trip screw counter clockwise. When set correctly, the trigger will hold 1 lb. 4 ozs. but trip at 1 lb. 6 ozs.

3. Readjust the trigger trip screw as in step 1 above, then check the trigger adjust screw as in step 2. Continue to check these steps alternately until certain that no further adjustment is necessary. Tighten all locknuts after each adjustment.

The zero and range adjustments described in the maintenance section should be checked at this point.

## OPERATION

With an ample supply of material in the storage bin, center a bag beneath the spout and raise it between the spout and the clamps. The clamps will hold the bag securely. Balance the bag by moving bag balancing weight 204 as required. Raise the weigh weight cover, 416, on the weight rod, 413, and place weigh weights on the weigh rod equivalent to the amount of material it is desired to weigh. Pull down on the feed gate handle until the trigger knife edge and bearing engage, then release the handle. Material will flow into the bag. As the bag fills and descends, the beam will touch the trigger trip screw, pulling the bearing from beneath the trigger knife edge to close the feed gate and cut off the material flow. Remove the bag by raising the bagholder release bar.

When greater accuracy is desired and speed is not important, set the trigger trip screw so that the weighings are consistently between one-half (1/2) and two pounds light, then hand trim by joggling the feed gate handle slightly until enough additional material has entered the bag to bring the pointer to the balance line on the indicator plate.

## REGULATING THE FEED RATE

Some materials are heavier than others and some flow more freely than others. When weighing a heavy material the area of the stream should be reduced; when weighing a light material the area



can be increased to obtain greater speed from the scale. An excessive feed rate will cause inaccurate weighings.

To control the feed rate a regulating slide and restrictor plate in the chute are provided. To increase the feed rate loosen wing nut on the regulating slide (see page 9 - mark 306 - handle has been replaced by a carriage bolt 3/8 NC x 1); move the bar down as required then tighten the wing nut. To decrease the feed rate, if there is material in the chute, loosen the wing nut and press upward against the wing nut with the left thumb, at the same time pull down slightly on the gate handle with the right hand and the regulating slide will immediately move toward close. Adjust as required and tighten wing nut. Whenever the position of the slide is changed, it usually will be necessary to reset the trigger trip screw as described below under "Compensation". If the scale is fed by a power feeder, the regulating slide must be full open and any adjustments made to the feeder regulating slide (if one is supplied). Sometimes the regulating slide, 305, on scale is omitted when the scale is fed by a power feeder.

The restrictor plate 320 has slotted holes for vertical adjustment. This has been set at the factory for 1/2" gate clearance. This is suitable for granular and pellet-type materials and lumps up to 3/8" in largest dimension. For materials containing large lumps not exceeding 5/8" in largest dimension, the gate clearance can be increased to a maximum of 1" by loosening the two mounting screws on the back of the chute. When raising or lowering the restrictor plate, adjust the 2 1/4" long round-head support screw in the center of the gate seal retaining bar so that it just touches the plate, providing positive backing. This will prevent the material stream from deflecting the restrictor plate; thus increasing the stream which in turn will cause pressure on the rubber seal, resulting in leakage.

For materials containing lumps, cubes, briquettes etc., in sizes larger than 3/4", the restrictor plate may be removed if desired, as these materials normally do not require feed stream openings less than 1 7/8", which is the minimum chute opening with

the restrictor plate removed and the regulating slide set at its minimum opening. If desired, the restrictor plate may be removed when the scale is fed by a power feeder.

If the restrictor plate is removed, use the mounting screws in the chute to plug the holes in the chute. The 2 1/4" round-head center screw should then be replaced by a 5/16" x 1 capscrew.

## POWER FEEDER

On power-fed scales, the regulating slide is usually omitted. If the scale is power-fed and a regulating slide has been provided, the slide should be fully open and the feed rate adjusted by means of the feeder regulating slide. If the feeder is not equipped with a regulating slide, adjust the speed of the feeder.

If the scale is fed by a power feeder, a limit switch will be mounted on the side of the scale housing. Its purpose is to start and stop the feeder. The switch is actuated by the heel of the trigger arm.

## COMPENSATION

The purpose of the compensating mechanism is to compensate for the material that flows into the bag from the moment the beam begins to move toward the balance position until the feed stream is completely cut off. The compensation cannot take into account variations in the column of material due to poor flow characteristics of the material. If the stream is inconsistent for any reason, this variation will be reflected in the weighings; they will be irregularly heavy or light.

Also refer to the paragraph entitled "Compensation Spring" in the Maintenance section.

The accuracy of a weighing may be tested by observing the pointer and indicator plate after the bag has been filled, or by weighing the full bag on a platform scale. In the latter instance allow for the weight of the bag. If the weighing is heavy or light, adjust the trigger trip screw. If the weighing is heavy, loosen the locknut and lower the trigger trip screw; if the weighing is light, raise the trigger trip screw. Tighten the locknut after each adjustment and before making each test weighing. Any change to the position of the trigger trip screw will not affect the weighing in the bag but will affect subsequent weighings. It will probably be necessary to make a few trial weighings before the correct setting is found. Never set this screw so that there is less than 1/8" clearance between the trigger trip screw and the beam when the beam is on its bottom stop.

### BALANCING SCALE EMPTY

See that the feed gate handle, 304, is closed and that there are no weigh weights on the weight rod 413. Move the bag balancing weight 204 near the end of its threaded rod. The small punchings or "shot" needed to balance out the beam system are either inside the balance box or packed separately in a cloth bag. If packed separately, lift weight box lid 414 and pour the punchings into the balance box. If packed inside the balance box, remove the seal that holds the lid on. Add or remove shot until balance indicator is on zero.

### BALANCING THE BAG

Place a bag on the spout. The scale is now out of balance and must be re-balanced with the bag on the spout. Turn the bag balance weight 204 (Figure 2) until the pointer points to the balance line on indicator plate.

When changing over from one bag to another of different weight, the bag balance weight must be adjusted to rebalance the scale.

If more than one bag spout is supplied with a scale, the spouts are made interchangeable at the factory. When the spout for different size bags is *changed*, only the bag must be balanced.

The test for empty balance should be made a part of the operating routine. It should be done at least once daily to maintain the accuracy that was built into the scale.

### COMPONENTS

**BAGHOLDER:** This "G17" is equipped with a camgrip bagholder.

**QUICK-CHANGE BAG SPOUT:** If quick-change bag spouts have been supplied, it is easy to change from one bag spout to another. Unlock the spout by turning the two handles 90°, then slide the spout in the slotted holes until the spout is free of the scale. To mount a different spout, bring it into position and slide it over the two bolts, then lock it in position by turning the two handles 90°.

**DASH POT:** Complete instructions and parts list for the dash pot will be found elsewhere in this manual.

**SWAY CONTROL LINK 423:** The purpose of the sway control link is to prevent the bag spout from swaying excessively, but at the same time allow it to move freely up and down.

**COUNTER:** A 5-figure setback counter may be supplied as optional equipment. If so, it will be mounted on the front of the scale and actuated by the closing of the feed gate. The counter counts to 99,999 and then returns to zero but can be reset to zero before then by turning the wing nut.

### MAINTENANCE

We suggest that the scale be checked at regular intervals to see that all adjustments which follow, and those covered in the section entitled "Procedure Before Operation" on page 2 should be reviewed.

### ZERO POSITION AND RANGE

The paragraphs which follow describe zero and range adjustment. Before making an adjustment it should be clearly understood that a change to one will necessitate a change to the other. For instance, after making a zero adjustment the range adjustment will have to be checked; if a change is made to the range adjustment, then go back to zero adjustment, then check range adjustment again, and so on until no further adjustments are necessary.

**ZERO POSITION ADJUSTMENT:** Push rod 408 is in two sections with a turnbuckle between. If the pointer does not point to the zero mark on the indicator plate when the weigh beam is level, block the beam in the level position, loosen the turnbuckle locknuts, rotate the turnbuckle in the required direction until the pointer is at zero, then tighten the locknuts. Remove the blocking from the beam. If the pointer moves off zero, the scale is not in correct empty balance. Refer to the section entitled "Balancing Scale Empty". Now check range adjustment.

**RANGE ADJUSTMENT:** After checking the zero adjustment, hang two pounds of test weights on the bagholder. If the pointer does not point to "2 lbs." on the indicator plate, loosen the nut holding push rod connecting pin 410 in its slot in the torsion rod, move it backward or forward as required, then tighten the push rod connection pin nut. As mentioned above, it will be necessary to check zero adjustment again.

**TORSION ROD ADJUST BOLT** If it is not possible to obtain satisfactory range adjustment by the means described in the preceding paragraph, loosen the nut holding the torsion rod adjust bolt, move the adjust bolt outward (a small amount)

in its slot, then tighten the nut. Check zero and range adjustments after adjusting torsion rod adjust bolt. It will probably be necessary to experiment in order to determine the correct setting.

**COMPENSATION SPRING**

With the beam on its bottom stop the compensation spring 419 will exert a force on the beam which tends to bring the beam to balance. As the beam rises off its bottom stop and the indicator pointer descends toward the balance position, the spring should stop exerting its force at the point where the indicator pointer passes the minus 2-lb. mark on the indicator plate. The spring was set at the factory and ordinarily its setting should not be changed. If, however, weighings are being made in the lower range of the scale's capacity, or if the scale is being fed on the stream, it may not be possible to obtain sufficient adjustment with the trigger trip screw. If this is the case, reduce the tension of the compensation spring by a small amount, then make the final adjustment by means of the trigger screw as described under "Compensation."

**BAG CLAMP ADJUST BOLTS**

There should always be 1/32" to 1/16" clearance between the bottom of each adjust bolt and top of each bag clamp when the bagholder is closed.

**BAGHOLDER RELEASE BAR**

To level the bagholder release bar, loosen bolt. Hold release bar in horizontal position and turn adjusting disc (Part No. 50437-5501) until it rests against bracket. Tighten bolt.

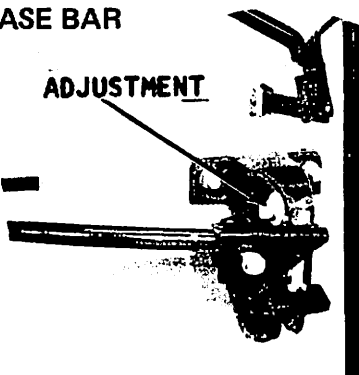

**CLEANING**

Any material which builds up on the feed gate and regulating slide should be removed at regular intervals. For access to these, remove the bag spout. This is easily done by removing the retaining pin, 421-B, and steeling, 421-A, on both sides of the scale, and the roll pin that connects the sway control link 423 to the spout. Particles of most materials that would adhere to the gates and chute can be removed with a stiff wire brush. When reassembling the bag spout, be certain that the V-grooves of the steelings\* rest on the beam end pivots. Or, as an alternative, remove the weight rod 413 from the beam, raise the protective clips 115 and tighten the bolts so that the bag spout cannot move, remove the entire scale from the bin or feeder and set it on the floor, then reach down from the top and clean the feed gate chute, etc.

Steelings, 420-A and 421-A, should also receive a periodic cleaning. Blow them out with an air nozzle, or, if the material is not easily dislodged, reach in with a small brush such as a toothbrush. A piece of fine emery cloth wrapped around a nail file may also be used if necessary.

\*Also called bearings.

**LUBRICATION**

**DASH POT**

Instructions for the dash pot are found in another section of this manual. For type of oil recommended, refer to "J" on the chart below.

**GATE BEARING**

On most scales, no lubrication is required. Where the nature of the material warrants it, however, pressure fittings are provided for the gate bearings. Frequency of lubrication will depend on operating conditions. Do not overlubricate. For type of lubricant recommended, refer to "C" on the chart below.

| SYMBOL | PARTS TO BE LUBRICATED                                    | METHODS OF APPLICATION                      | RECOMMENDED LUBRICANTS        |                           |                      |                   |                           |
|--------|---|---|-------------------------------|---------------------------|----------------------|-------------------|---------------------------|
|        |   |   | Humble Oil & Refining Company | Mobil Oil Company         | Shell Oil Company    | Texaco Inc.       | Keystone Lubrica. Company |
| C      | Ball, Roller, Plain Bearings Rotating or Sliding Surfaces | Grease Cups, Pressure Fittings Hand Applied | Nebula EP 1                   | Mobilux Grease No. 2      | Alvania Grease No. 1 | Multi-fak 2       | No. 84 Light              |
| J      | Air Cylinders & Dash Pots                                 | Line Oiler, Bath                            | Nuto 50                       | Gargoyle Arctic Oil Light | Clavus Oil 29        | Regal Oil A R & O | Keystone KLC 6            |



## HOW TO USE THE PARTS LIST

Parts lists may cover a few variations of a model, therefore, some of this material may not apply to your order.

Recommended spare parts are indicated; if these replacements are kept in stock, valuable time will be saved if a breakdown should occur. Prices will be quoted on request. Common hardware is not listed unless it is reworked or made specially for HOWE RICHARDSON SCALE COMPANY.

The photograph or drawing that illustrates each part is shown. Illustrations contain MARK numbers which coincide with identical numbers in the last column of the parts list. When parts are to be ordered from a drawing instead of from a parts list, a copy of the drawing will be supplied with the manual and will include full information. If an electrical control panel was supplied, look on the inside for stenciled instructions.

We have many parts in stock, and prompt shipment can be made if we receive full information. Please review the following procedure before ordering parts.

### ORDERING

- 1) Study the equipment carefully. Become familiar with its many components.
- 2) Find the illustration that shows the parts you want to order.
- 3) Compare the parts with the illustration to establish positive identification.
- 4) Specify the complete "PART NO."
- 5) Specify the complete "NAME OF PART".
- 6) Specify the quantity of each part you require.

### CAUTION

These parts lists were compiled for the equipment identified on the cover of this manual. They should not be used for other Howe Richardson equipment regardless of its similarity.

### CODE

- A - For breakdown, see parts indented below assembly (asy.)
- B - Recommended spare part to keep in stock.
- C - Mating parts should be ordered together in sets.
- D - When qualified personnel and tools are not available to service this part, order the complete assembly if possible, otherwise call for Howe Richardson service.
- E - Part No. will vary, when ordering, specify mark no. instead.
- H - This part is not illustrated.

The following G17 repair kits are available from the Howe Richardson parts department.

- 600048-3402 G-17 Cam Grip Bagholder Repair Kit for Octagon Spout
- 600048-3403 G-17 Trigger Assembly Repair Kit
- 600048-3404 G-17 Dash Pot Repair Kit
- 600048-3405 G-17 Main Beam/Steeling Repair Kit



**FIGURE 1**  
**PARTS LIST – OVERALL FRONT VIEW AND BAGHOLDER**

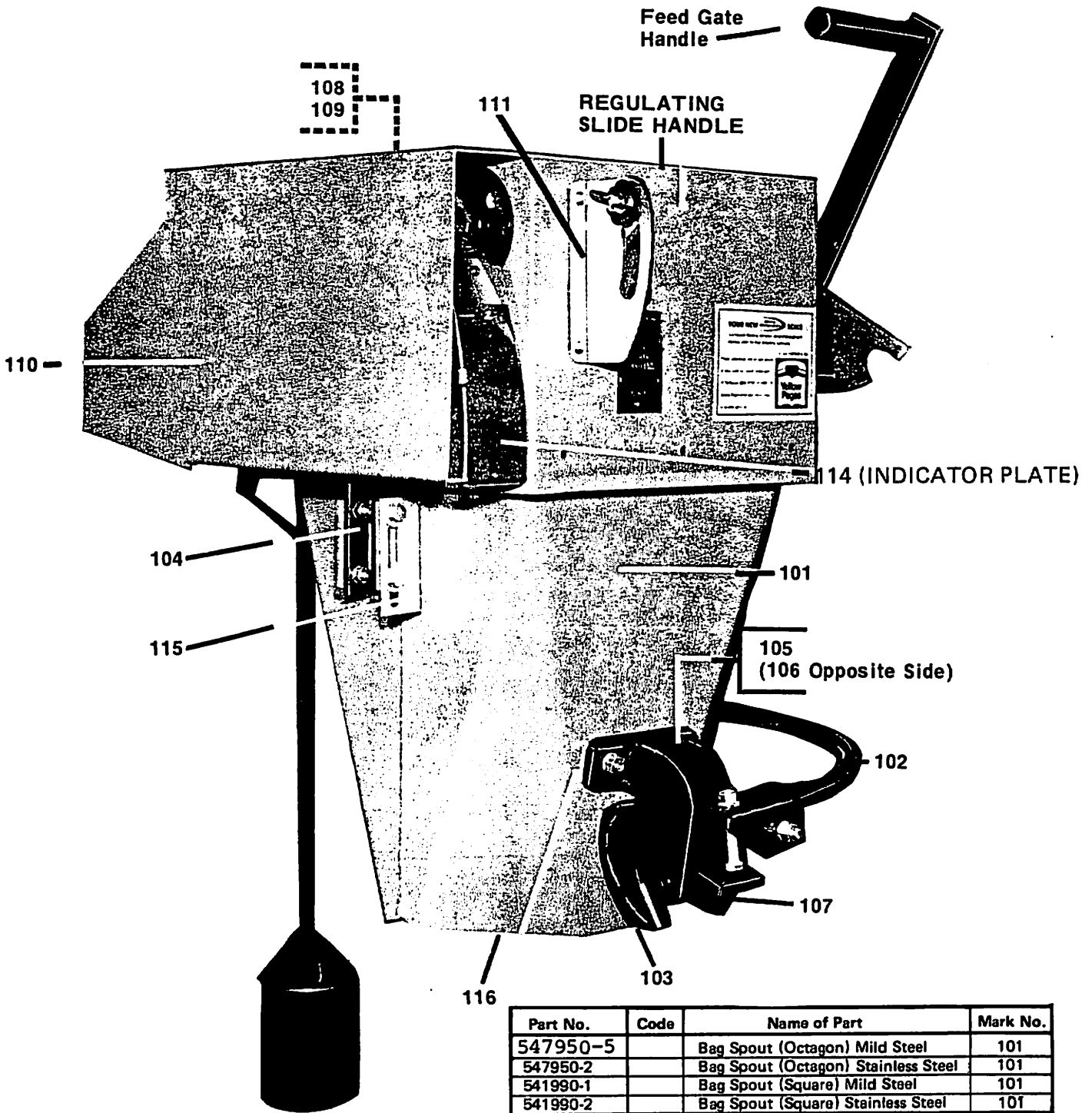

| Part No.    | Code | Name of Part                        | Mark No. |
|-------------|------|-------------------------------------|----------|
| 547950-5    |      | Bag Spout (Octagon) Mild Steel      | 101      |
| 547950-2    |      | Bag Spout (Octagon) Stainless Steel | 101      |
| 541990-1    |      | Bag Spout (Square) Mild Steel       | 101      |
| 541990-2    |      | Bag Spout (Square) Stainless Steel  | 101      |
| 546022-7    |      | Bagholder Release Bar (Octagon)     | 102      |
| 546022-3    |      | Bagholder Release Bar (Square)      | 102      |
| 536318-1    |      | Bag Clamp                           | 103      |
| 545448-1    |      | Spout Suspension Shackle            | 104      |
| 47936-0101  |      | Rear Bagholder Bracket (Octagon)    | 105      |
| 36317-0101  |      | Rear Bagholder Bracket (Square)     | 105      |
| 47935-0101  |      | Front Bagholder Bracket (Octagon)   | 106      |
| 36316-0101  |      | Front Bagholder Bracket (Square)    | 106      |
| 449660      | B    | Bag Clamp Fulcrum Pin               | 107      |
| 37983-3601  | H    | Slide Bar Spacer                    | 108      |
| 37982-3601  | H    | Slide Bar                           | 109      |
| 050574-3501 |      | Side Cover                          | 110      |
| 41818-3501  |      | Regulating Slide Adjusting Plate    | 111      |
| 50437-5501  |      | Disc, Adjusting                     | 112      |
| 767540      |      | Balance Indicator Plate             | 114      |
| 39825-3501  |      | Protective Spout Clip               | 115      |
| 46401-3501  |      | Shims                               | 116      |

767538 (METRIC)

**FIGURE 2**  
**PARTS LIST – TRIGGER ARM**

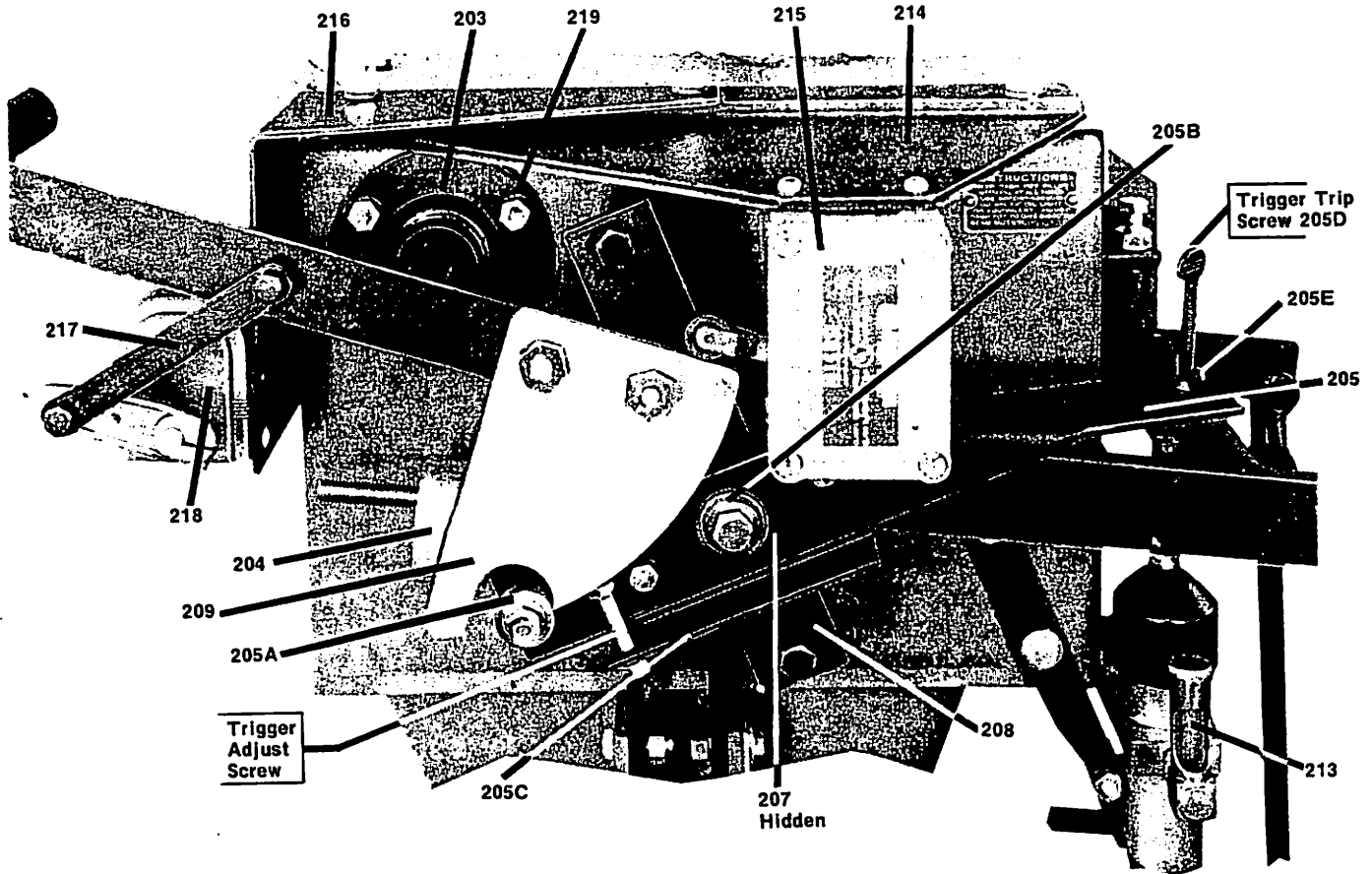

| Part No.   | Code | Name of Part                  | Mark No. |
|--|------|-------------------------------|----------|
| 705225   | B    | Bearing, AG1100D              | 203      |
| 37970 -6601  |      | Bag Balance Weight            | 204      |
| 546023-01  | A    | Trigger Arm Asy. Complete     | 205      |
| 705555   | B    | Bearing, 88007 (Trigger Arm)  | 205A     |
| 50583-7801   |      | Bearing, 488500 (Trigger Arm) | 205B     |
| 42376-3501   |      | Bearing Bracket (Trigger Arm) | 205C     |
| 474344   |      | Trip Screw (Trigger Arm)      | 205D     |
| 442595   |      | Wing Nut (Trigger Arm)        | 205E     |
| 3314-6634  | H    | Spacer                        | 207      |
| 42379-3601   |      | Trigger Arm Mounting Bracket  | 208      |
| 42375-7001   |      | Trigger Knife Edge            | 209      |
| 732900   | BJ   | Dash Pot Oil*                 | 213      |
| <b>The following parts are supplied only with limit switch attachment.</b> |      |                               |          |
| 43823-3501   |      | Switch, Mounting Plate        | 214      |
| 279580   | B    | Switch, Micro EXAR            | 215      |
| <b>The following parts are supplied only with the counter attachment</b>   |      |                               |          |
| 43821-3501   |      | Counter Mounting Bracket      | 216      |
| 43822-3601   |      | Counter Connecting Link       | 217      |
| 44392-2501   | B    | Counter                       | 218      |
| 762316   | B    | Bearing "SEALMASTER" SFT-16   | 219      |

\*See lubrication chart - page 5.

**FIGURE 3  
CHUTE (BOTTOM VIEW)**

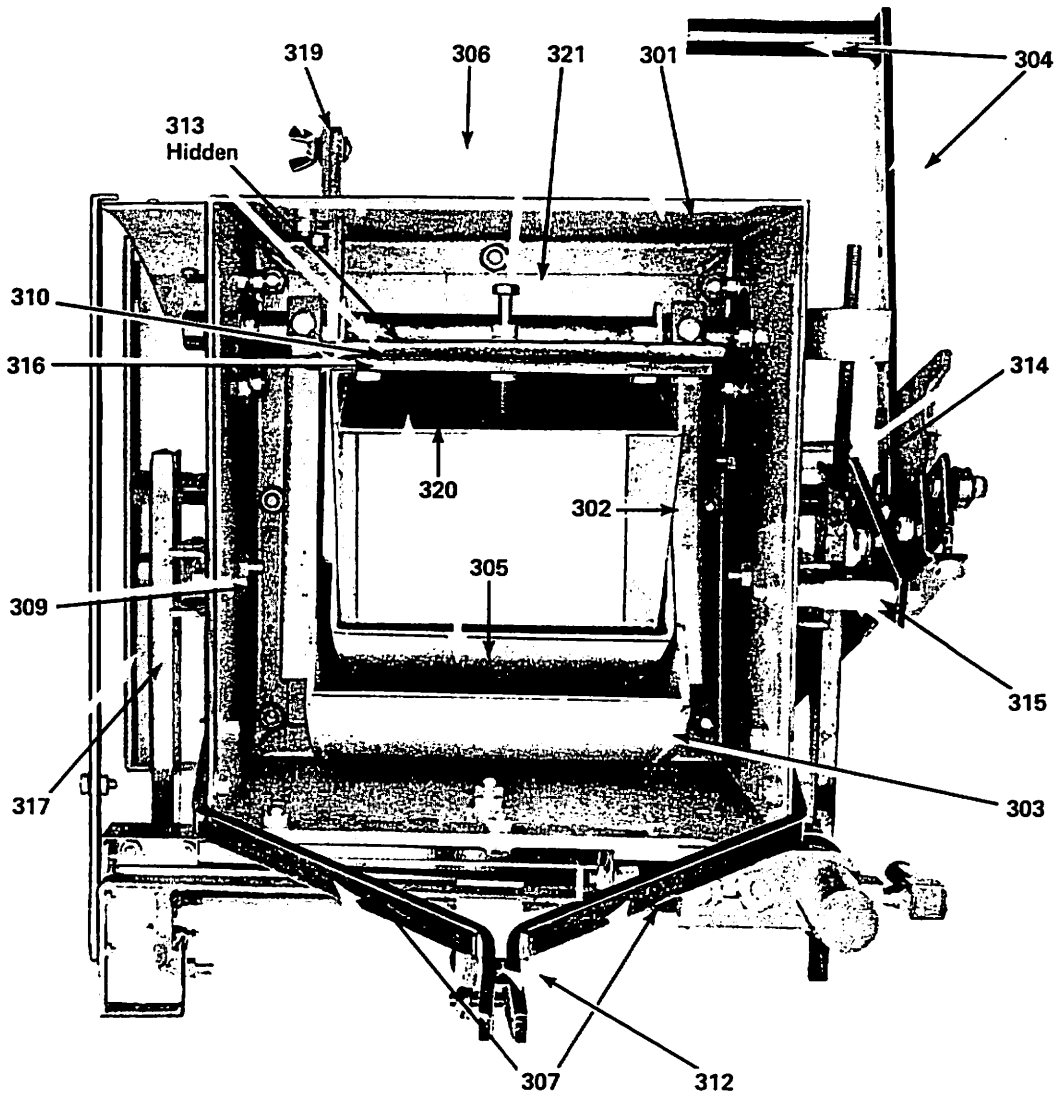

| Part No.   | Code | Name of Part                       | Mark No. |
|------------|------|------------------------------------|----------|
| 542425-1   |      | Housing                            | 301      |
| 541815-1   |      | Chute (Mild Steel)                 | 302      |
| 541815-2   |      | Chute (Stainless Steel)            | 302      |
| 542391-1   |      | Chute Gate (Mild Steel)            | 303      |
| 542391-3   |      | Chute Gate (Stainless Steel)       | 303      |
| 542426-1   |      | Feed Gate Handle                   | 304      |
| 541822-1   |      | Regulating Slide (Mild Steel)      | 305      |
| 541822-2   |      | Regulating Slide (Stainless Steel) | 305      |
| 404229     |      | Bolt, Carriage 3/8 NC x 1          | 306      |
| 546019-1   |      | Sway Control Bracket               | 307      |
| 38136-3501 |      | Middle Bearing Bracket Shim        | 309      |
| 37994-3601 |      | Gate Stop Bar                      | 310      |
| 3314-6634  |      | Sway Control Spacer                | 312      |
| 36835-3601 | H    | Chute Seal Spacer                  | 313      |
| 3405-3614  |      | Spacer                             | 314      |
| 3405-3626  |      | Spacer                             | 315      |
| 2425-7910  | B    | Chute Seal                         | 316      |
| 442515     |      | Wing Nut                           | 319      |
| 46760-3501 |      | Restrictor Plate (Mild Steel)      | 320      |
| 46760-5501 |      | Restrictor Plate (Stainless Steel) | 320      |
| 469796     |      | Adjusting Screw (Mild Steel)       | 321      |
| 470655     |      | Adjusting Screw (Stainless Steel)  | 321      |

**FIGURE 4**  
**PARTS LIST – OVERALL REAR VIEW**

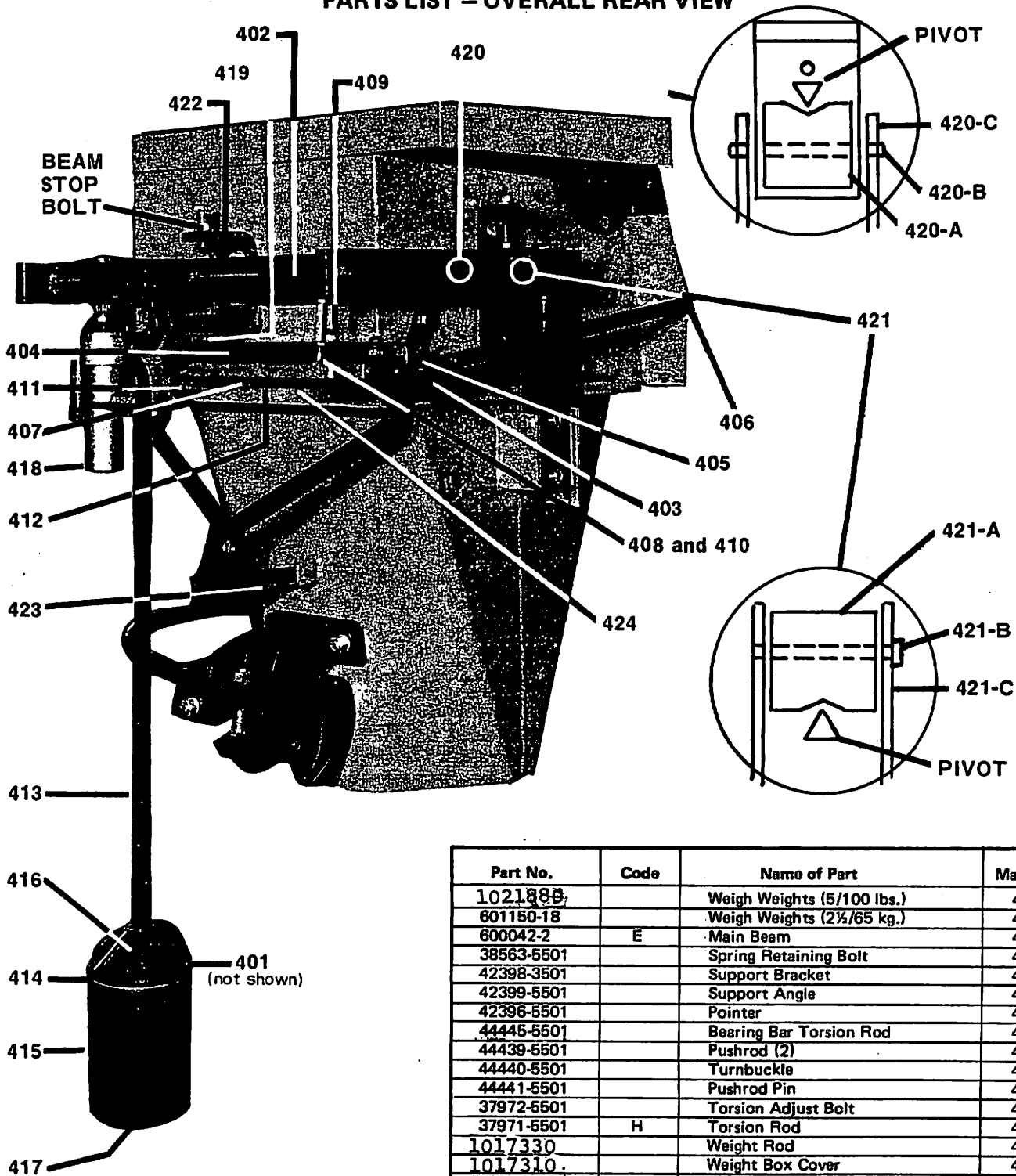

| Part No.   | Code | Name of Part                      | Mark No. |
|------------|------|-----------------------------------|----------|
| 1021888    |      | Weigh Weights (5/100 lbs.)        | 401      |
| 601150-18  |      | Weigh Weights (2 1/4/65 kg.)      | 401      |
| 600042-2   | E    | Main Beam                         | 402      |
| 38563-5501 |      | Spring Retaining Bolt             | 403      |
| 42398-3501 |      | Support Bracket                   | 404      |
| 42399-5501 |      | Support Angle                     | 405      |
| 42396-5501 |      | Pointer                           | 406      |
| 44445-5501 |      | Bearing Bar Torsion Rod           | 407      |
| 44439-5501 |      | Pushrod (2)                       | 408      |
| 44440-5501 |      | Turnbuckle                        | 409      |
| 44441-5501 |      | Pushrod Pin                       | 410      |
| 37972-5501 |      | Torsion Adjust Bolt               | 411      |
| 37971-5501 | H    | Torsion Rod                       | 412      |
| 1017330    |      | Weight Rod                        | 413      |
| 1017310    |      | Weight Box Cover                  | 414      |
| 926578     |      | Weight Box                        | 415      |
| 925040     |      | Weight Box Lid Cone               | 416      |
| 449190     | H    | Roll Pin, Weight Rod              | 417      |
| 600047-1   | A    | Dash Pot Complete Assy. (Page 11) | 418      |
| 781127     |      | Compensation Spring               | 419      |
| 546016-1   | A    | Asy. Middle Bearing Bkt.          | 420      |
| 9835-3801  | B    | Bearing                           | 420-A    |
| 449209     | B    | Rollpin                           | 420-B    |
| 37964-3601 |      | Bracket                           | 420-C    |
| 546017-1   | A    | Shackle, Support Suspension Asy.  | 421      |
| 9835-3801  | B    | Bearing                           | 421-A    |
| 38115-6601 | B    | Pin, Retaining                    | 421-B    |
| 545448-1   |      | Suspension Shackle                | 421-C    |
| 546018-1   |      | Beam Stop Bracket                 | 422      |
| 42394-3601 |      | Sway Control Link                 | 423      |
| 44442-5501 | H    | Clamp Washer                      | 424      |

# DASH POT INSTRUCTIONS AND PARTS LIST

## OPERATION

The Howe Richardson dash pot is an enclosed unit containing a piston which moves up and down in an oil bath. The piston rod is linked to the weigh beam of a scale (or to any lever which moves alternately) to cushion the number of oscillations.

**NOTE:** Make sure there is an ample supply of fluid in the dash pot before operating.  
Dow Corning No. 200 500 C.S.

## ADJUSTMENT

The piston rod is linked to the weigh beam of a scale or to any lever which moves alternately to cushion the number of oscillations.

To adjust the dampening effect of the dash pot on the beam or lever:

If the beam oscillates too freely, loosen the wing nut 112, and turn the adjust nut down. There are four holes in disc 103. Turning the adjust nut down decreases the gap between spring cap 105 and the disc. This restricts the flow of oil through the holes thereby increasing the damping effect.

If the beam oscillates too sluggishly, or not at all, turn the adjust nut up. When the adjustment is satisfactory, lock the wing nut.

When the dash pot is linked to the weigh beam of a Howe Richardson automatic scale, the adjustment should be made with the weigh hopper full. After the beam reaches cutoff, or the balance point, it should make one complete oscillation before the dash pot arrests the beam motion.

## MAINTENANCE

### CLEANING

It is suggested that the dash pot be cleaned at least once yearly. To do this, detach the cylinder and clamp, 100, from the dash pot mounting bracket. Pour out the lubricant, then clean the parts in kerosene to remove any sludge. Re-assemble as shown in the illustration and add new oil.

### DASH POT OIL

A small can of fluid is usually supplied with the unit. Before purchasing the fluid, refer to symbol "N" in the lubrication chart enclosed. Remove the cap from the oiler, 109 and pour the oil in slowly until the fluid level is mid-point in the glass.

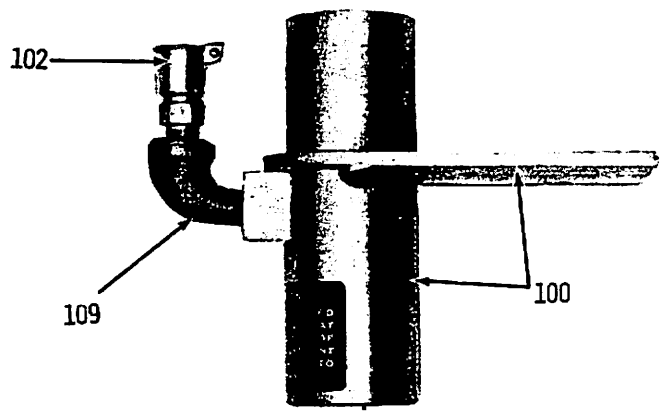
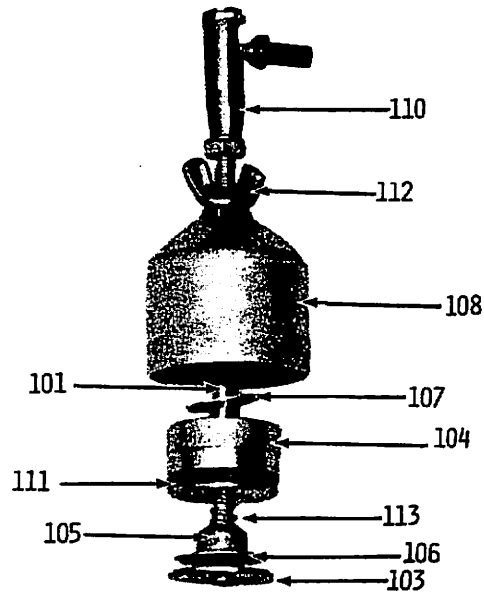

| PARTS LISTS |      |                               |          |
|-------------|------|-------------------------------|----------|
| Part No.    | Code | Name of Part                  | Mark No. |
| *602972-1   |      | Dash Pot Complete (No Fluid)* |          |
| 550704-1    |      | Cylinder and Clamp            | 100      |
| 38179-7001  |      | Spacer                        | 101      |
| 550707-1    |      | Piston Disc Assy.             | 103      |
| 38179-6001  |      | Dash Pot Cover                | 104      |
| 720600      |      | Dash Pot Spring Cap           | 105      |
| 782595      | .B   | Spring                        | 106      |
| 494012      |      | Dust Seal Washer              | 107      |
| 538175-1    |      | Dash Pot Cap                  | 108      |
| 728425      |      | Oiler                         | 109      |
| *742807     |      | Ball Joint                    | 110      |
| 755106      | B    | O-Ring                        | 111      |
| 442625      |      | Wing Nut                      | 112      |
| 782070      | B    | Spring                        | 113      |

\*Above parts list is for mild steel scales - stainless steel parts are the same except: 600047-1 complete dash pot and 742805 ball joint.

\*Silicone Fluid Part Number - 732 900

|  |   |
|--|---|
| DEPT.  | NO. <b>S-48001-G17</b>  |
| H. E. & CO. OGD. NO.   | DATE CERTIFIED  |
| CERTIFIED BY   | CUSTOMER  |
| CUSTOMER'S OGD. NO.  | TITLE   |
|  | <b>OUTLINE ARRANGEMENT OF G-17 GROSS RAGGER WITH OCTAGONAL SPOUT (11 1/2" X 7")</b> |
| DESIGNED BY  | DATE  |
| DRAWN BY   | <b>5-24-69</b>  |
| SCALE  | <b>3"-1'-0"</b>   |
| HOWE RICHARDSON SCALE COMPANY<br>CLIFTON, NEW JERSEY, U.S.A. |   |
| FILED  | <b>S-48001-G17</b>  |
| BY   |   |

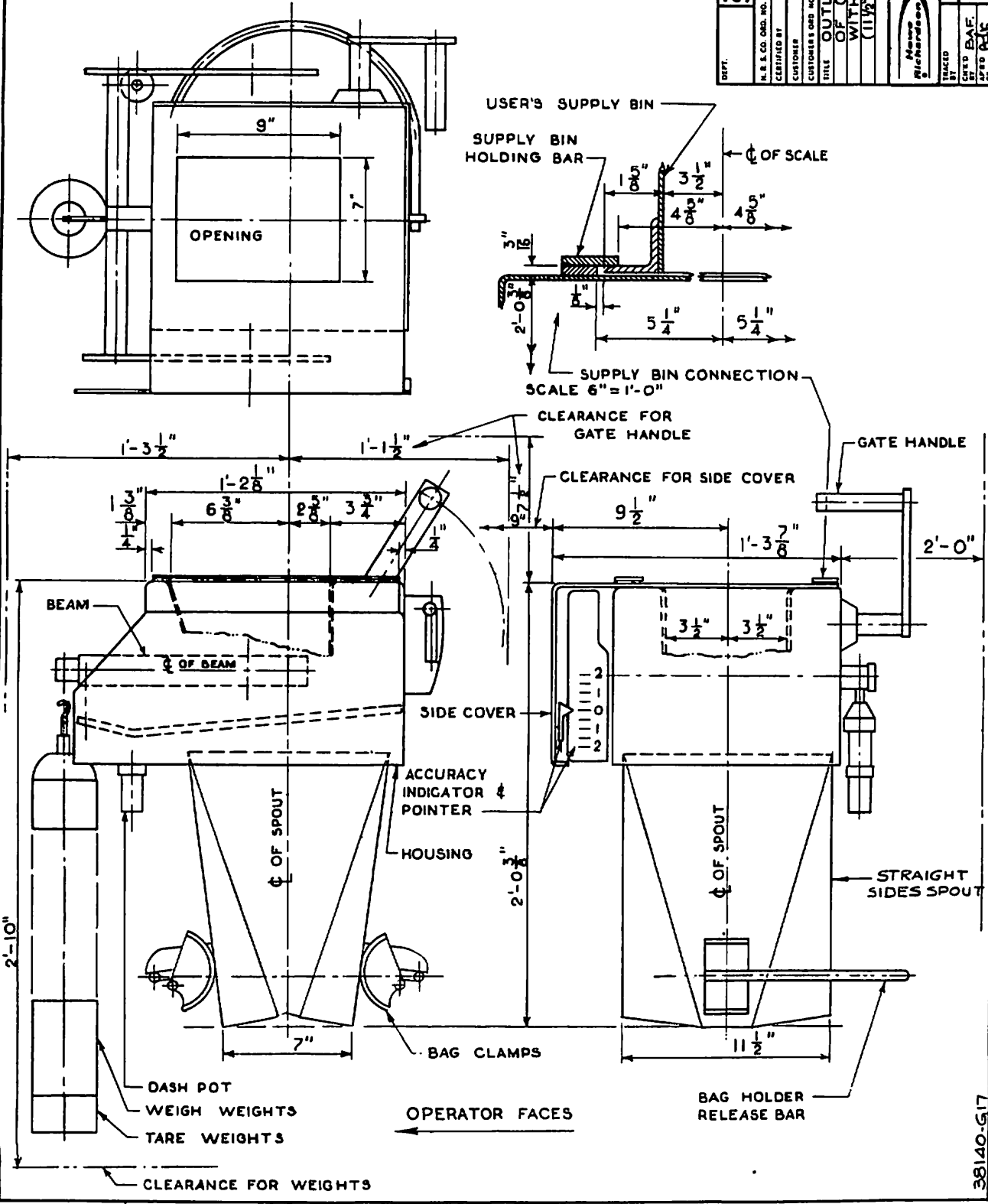

38140-G17