

DAVE FISCHBEIN COMPANY  
2700 - 30TH AVENUE SOUTH  
MINNEAPOLIS, MINN. 55406  
(612) 721-4806

FISCHBEIN BAG CLOSER  
INSTRUCTIONS AND PARTS MANUAL

SEWING HEAD:

MODEL NO. 10,300

SERIAL NO. \_\_\_\_\_

The Don Marshall Company, Inc.  
235 Maple Street - PO Box 124  
Plain City, Ohio 43064  
614-873-8520, Fax: 614-873-8338  
info@donmarshall.net



## INSTALLATION

### MOTOR RECOMMENDATIONS

USE A 1/2 H.P. 1725 R.P.M. MOTOR. THE VARIABLE PULLEY ON THE SEWING HEAD PERMITS SPEED ADJUSTMENT. SEWING HEAD PULLEY MUST ROTATE CLOCKWISE.

### INITIAL LUBRICATION

THE SEWING HEAD IS SHIPPED FROM THE FACTORY OIL FILLED. AT THE BEGINNING OF EACH DAY OR SHIFT, MAKE SURE THE OIL LEVEL WINDOW AT THE LOWER PORTION OF THE SEWING HEAD SHOWS OIL AT THE "OIL LEVEL" LINE. AFTER ABOUT 30 SECONDS, THE OIL PRESSURE GAUGE SHOULD READ IN THE NORMAL 3 - 9 POUND RANGE. WHILE THE MACHINE IS RUNNING, THE OIL LEVEL WINDOW WILL SHOW LITTLE OR NO OIL. NEVER RUN MACHINE IF OIL PRESSURE GAUGE IS IN THE RED WARNING AREA.

## MAINTENANCE

### OIL

USE SPECIAL LUBRICATION OIL FOR THE SERIES 10,000 SEWING HEAD AVAILABLE FROM THE DAVE FISCHBEIN COMPANY OR ITS AUTHORIZED REPRESENTATIVES. AS A SUBSTITUTE, ANY GOOD GRADE OF SAE 20 MOTOR OIL OR ITS EQUIVALENT MAY BE USED. EIGHT OUNCES OF OIL WILL ADEQUATELY FILL THE MACHINE.

WHEN ADDING OR CHANGING OIL, REMOVE BREATHER PLUG AND POUR OIL INTO BREATHER PLUG HOLE. FILL UNTIL OIL REACHES "OIL LEVEL" LINE ON THE OIL WINDOW. NEVER RUN MACHINE IF OIL PRESSURE GAUGE IS IN THE RED WARNING AREA. SEE DRAWING 1.

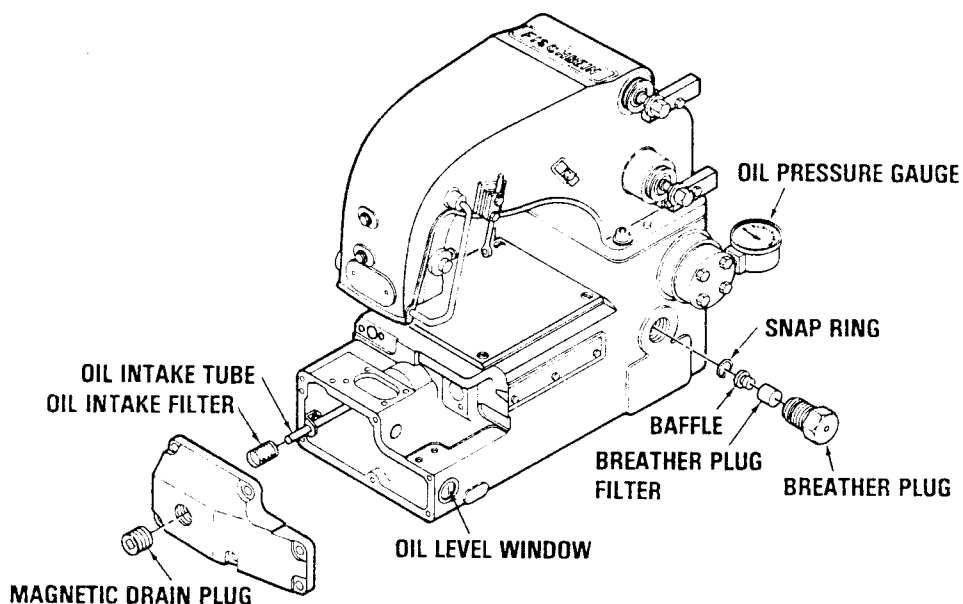

DRAWING 1

TO DRAIN OIL, REMOVE MAGNETIC DRAIN PLUG AND ALLOW OIL TO DRAIN. AT OIL CHANGE INTERVALS, ALSO CLEAN OIL INTAKE FILTER AND WIPE ANY ACCUMULATION OF PARTICLES OFF MAGNETIC DRAIN PLUG. INSPECT BREATHER PLUG AT LEAST ONCE A YEAR AND CLEAN OR REPLACE FOAM FILTER ELEMENT. CHANGE OIL EVERY TWO MONTHS OR 500 HOURS OF OPERATION, WHICHEVER COMES FIRST.

### SEALS

ALL SEALS MUST BE HANDLED WITH EXTREME CAUTION. ANY SMALL AMOUNT OF DAMAGE IN HANDLING OR INSTALLATION WILL PERMIT LEAKAGE. WHEN REPLACING A SEAL, SATURATE BOTH IT AND THE SHAFT THOROUGHLY WITH OIL BEFORE ASSEMBLING. NEVER INSTALL A DRY SEAL OVER A DRY SHAFT.

### CLEANING

REMOVE ACCUMULATIONS OF LINT FROM LOOPER AREA. IF PERMITTED TO REMAIN FOR LONG PERIODS OF TIME, THESE CAN SET UP A WICKING ACTION WHICH WILL ABSORB OIL FROM THE MACHINE. IF THE MACHINE IS OPERATED AROUND CORROSIVE OR STICKY PRODUCTS, OCCASIONALLY BLOW OFF OR SCRAPE SUCH EXPOSED PARTS AS THE FEED DOG, THROAT PLATE AND PRESSER FOOT. ALSO RECOMMENDED IS PERIODIC HAND OILING OF PRESSER FOOT HINGE BOLT AND SURFACES OF CUTTING KNIFE.

### COLD AREA OPERATION

IN VERY COLD AREAS ALLOW MACHINE TO WARM UP BY RUNNING STEADILY FOR A FEW MINUTES BEFORE CLOSING ANY BAGS. FAILURE TO DO THIS, ESPECIALLY WITH UNITS RUNNING ON SINGLE PHASE CURRENT, CAN RESULT IN SLOW STARTING AND RUNNING OF SEWING HEAD. THIS CAUSES MIS-SYNCHRONIZATION WITH THE SPEED OF THE CONVEYOR BELT WHICH WILL BREAK THREAD AND CAUSE SEWING PROBLEMS UNTIL THE SEWING HEAD AND MOTOR WARM UP AND ATTAIN PROPER SPEED.

### RUNNING AFTER PROLONGED SHUT-DOWN

AFTER PROLONGED SHUT-DOWN PERIODS, THE SEWING HEAD OIL SHOULD BE PUMPING PROPERLY AND THE SEWING HEAD AND MOTOR WARMED UP BEFORE CLOSING ANY BAGS. THIS IS EASILY ACCOMPLISHED BY RUNNING THE SEWING HEAD IN SHORT 2 - 3 SECOND CYCLES UNTIL THE OIL PRESSURE GAUGE READS IN THE NORMAL 3 - 9 POUND RANGE.

## ADJUSTMENTS

### INITIAL SEWING

WHEN THERE IS NO THREAD CHAIN FORMATION, SEWING MUST BEGIN ON MATERIAL. RAISE THE PRESSER FOOT BY PUSHING THE LIFTER LEVER AND PLACE MATERIAL UNDER THE PRESSER FOOT. CHECK THE LOOPER TO MAKE SURE NO THREAD IS TANGLED AROUND IT AS A RESULT OF RUNNING THE MACHINE WITHOUT A THREAD CHAIN FORMATION.

## THREADING

FOLLOW THE THREADING DIAGRAM BELOW FOR PROPER THREADING. BE SURE LOOPER THREAD PASSES THROUGH BOTH HOLES OF THE LOOPER.

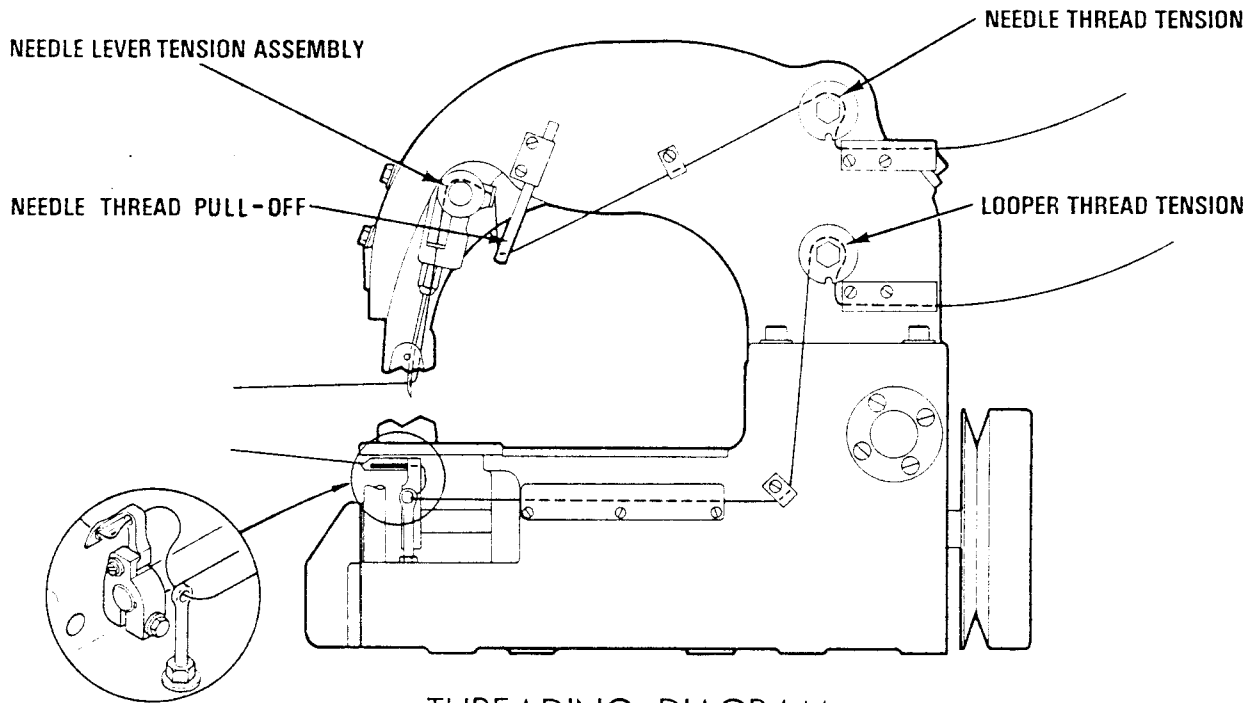

THREADING DIAGRAM

DRAWING 2

## TENSIONS

THE LOOPER TENSION MUST BE VERY LIGHT, BARELY DISCERNIBLE WHEN PULLING THREAD BY HAND. THE NEEDLE THREAD TENSION SHOULD BE VERY FIRM AND PUT A NOTICEABLE DRAG ON THE THREAD. THE TENSION ASSEMBLY LOCATED ON THE NEEDLE LEVER MUST PUT ONLY LIGHT PRESSURE, ABOUT THE SAME AS THE LOOPER TENSION, ON THE THREAD.

## NEEDLE REPLACEMENT

BE SURE NEW NEEDLE IS INSERTED INTO THE NEEDLE CHUCK AS FAR AS IT WILL GO. LOCK NEEDLE SET SCREW AGAINST FLAT OF NEEDLE SHANK. CAUTION: USE THE SMALL NEEDLE WRENCH PROVIDED WITH THE MACHINE. EXCESSIVE PRESSURE ON NEEDLE SET SCREW CAN DAMAGE SCREW OR NEEDLE CHUCK.

## STITCH LENGTH

TO ADJUST STITCH LENGTH, REMOVE THE MAGNETIC DRAIN PLUG ON THE BOTTOM COVER. REACH THROUGH THE DRAIN PLUG HOLE WITH A 3/16 INCH ALLEN WRENCH AND LOOSEN THE SOCKET CAP SCREW ON THE FEED ROCKER. DO NOT COMPLETELY REMOVE CAP SCREW. TO SHORTEN STITCH LENGTH, SLIDE LOOSENED CAP SCREW TOWARDS THE THROAT PLATE. TO LENGTHEN STITCH, SLIDE AWAY FROM THROAT PLATE. ALWAYS MAKE SURE ADJUSTING SCREW IS SECURELY RE-TIGHTENED. FOR STITCH LENGTH OF TWO STITCHES PER INCH, USE OPTIONAL THROAT PLATE 10302 AND FEED DOG 10079. SEE DRAWING 3.

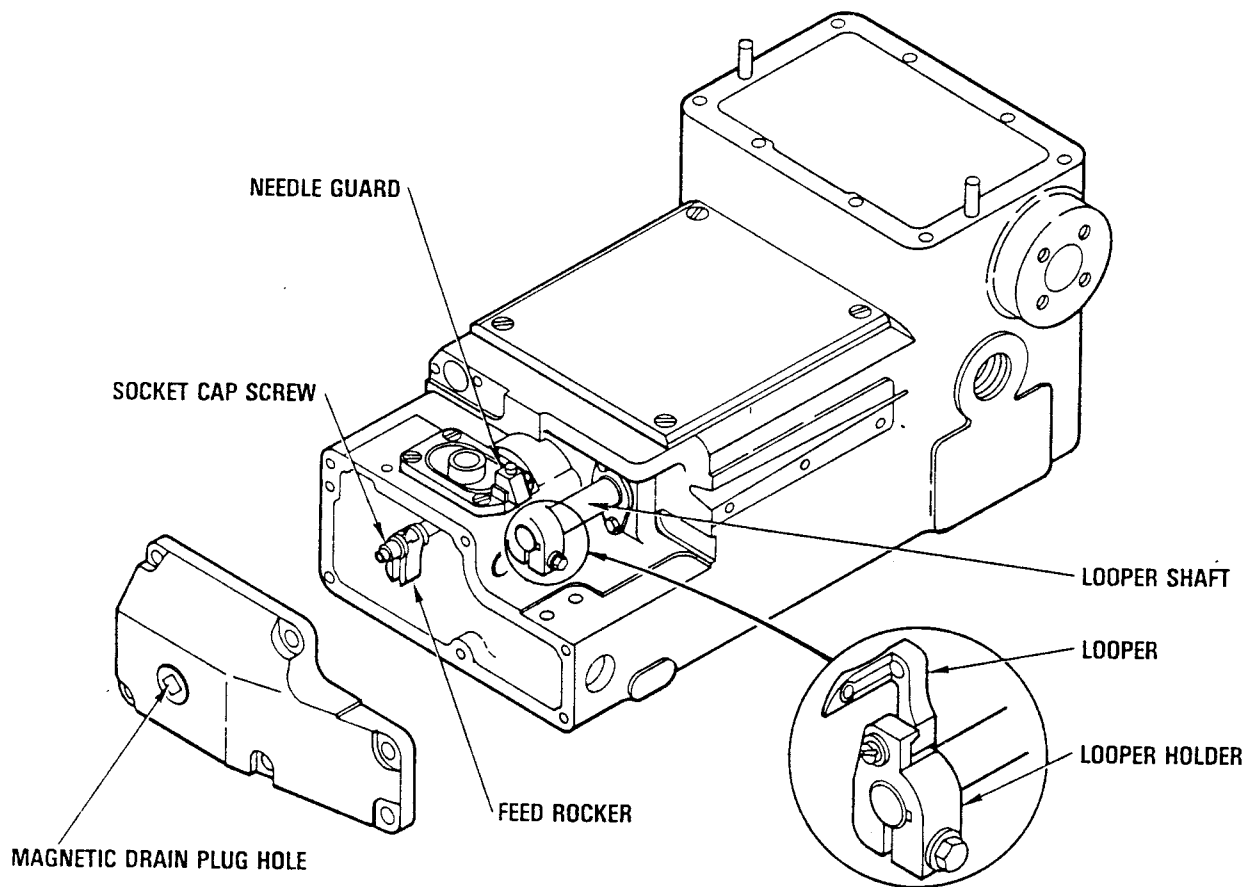

DRAWING 3

## NEEDLE THREAD PULL-OFF

THIS ADJUSTMENT CAN VARY WITH DIFFERENT LENGTHS OF STITCH, BAG THICKNESS AND TYPE OF THREAD. THE NORMAL SETTING IS 1-1/4 INCHES FROM CENTER OF THREAD HOLE IN PULL-OFF TO THE BOTTOM OF PULL-OFF CLAMP.

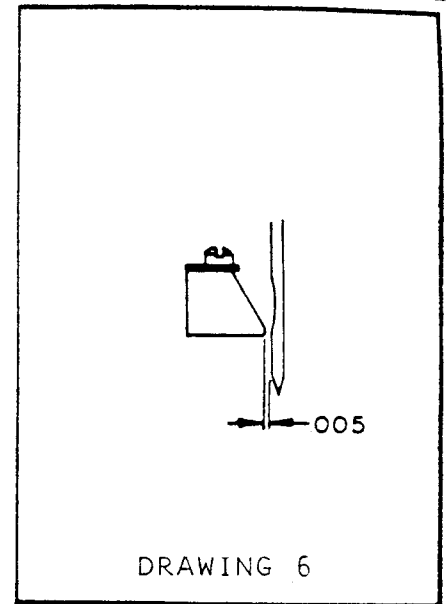
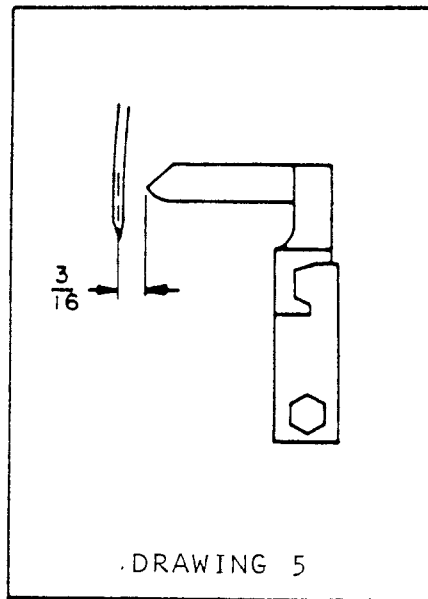
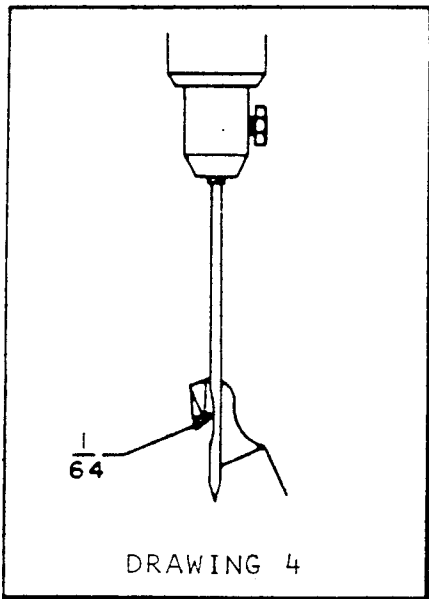

### LOOPER

THE LOOPER TIMING IS SET AT THE FACTORY AND SHOULD NEVER BE ALTERED. IF THE LOOPER ONLY IS REPLACED AND THE POSITION OF THE LOOPER HOLDER HAS NOT CHANGED, THE ONLY ADJUSTMENT NECESSARY IS TO PROVIDE THE PROPER CLEARANCE OF ABOUT 1/64" AS THE LOOPER PASSES THE SCARF OF THE NEEDLE. SEE DRAWING 4 ABOVE.

### LOOPER HOLDER

IF THE LOOPER HOLDER HAS BEEN MOVED AND NEEDS RESETTING, IT MUST BE POSITIONED ON THE LOOPER SHAFT SO THAT THE POINT OF THE LOOPER IS 3/16" FROM THE CENTER OF THE NEEDLE WHEN THE LOOPER IS AT ITS FARTHEST POINT BACK (TOWARDS THE PULLEY END OF MACHINE). SEE DRAWING 5 ABOVE.

### NEEDLE GUARD

THE NEEDLE GUARD IS STATIONARY AND NEEDS NO ADJUSTMENT. IF IT IS REPLACED DUE TO EXCESSIVE WEAR OR DAMAGE, IT SHOULD BE SET SO THAT THE NEEDLE CLEARS IT BY ABOUT .005". SEE DRAWING 6 ABOVE.

### PRESSER FOOT SPRING PRESSURE

TO ADJUST PRESSER FOOT SPRING PRESSURE, TURN THE HEX ADJUSTING SCREW ON TOP OF THE LEVER HOUSING. TURNING THE SCREW CLOCKWISE WILL INCREASE THE PRESSURE, COUNTER-CLOCKWISE WILL DECREASE PRESSURE. THE PRESSURE HAS BEEN SET AT THE FACTORY AT ABOUT 40 POUNDS, WHICH SHOULD BE ADEQUATE FOR MOST PURPOSES.

## FEED DOG HEIGHT

THE TEETH OF THE FEED DOG SHOULD PROTRUDE 1/16" ABOVE THE THROAT PLATE WHEN AT THEIR HIGHEST POINT. NO HEIGHT ADJUSTMENT OF THE FEED DOG SHOULD BE NECESSARY WHEN REPLACING IT. HOWEVER, IF THE DOG HAS BEEN RE-SHARPENED OR IS BEING RAISED TO COMPENSATE FOR WORN TEETH (NOT RECOMMENDED PROCEDURES), IT WILL BE NECESSARY TO LOOSEN THE FEED DOG CARRIER ROD CLAMP AND RAISE THE FEED DOG CARRIER ROD TO RESTORE THE PROPER 1/16" HEIGHT OF THE FEED DOG TEETH ABOVE THE THROAT PLATE. BE SURE TO ALIGN THE FEED DOG PROPERLY IN THE SLOTS OF THE THROAT PLATE BEFORE SECURELY LOCKING THE FEED DOG CARRIER ROD.



TROUBLE SHOOTER  
FOR FISCHBEIN MODEL 10,300 BAG CLOSER

A. SYNCHRONIZATION

THE SEWING HEAD MUST BE SYNCHRONIZED WITH THE CONVEYOR BELT. A MODEL 10,300 SEWING HEAD SHOULD RUN AT THE SAME SPEED OR SLIGHTLY SLOWER THAN THE CONVEYOR. IF A POWER TOP FEED IS USED, IT MUST ALSO BE SYNCHRONIZED WITH THE CONVEYOR. ALL CONVEYOR MODELS ARE PROPERLY SYNCHRONIZED AT THE FACTORY, BUT DIFFERENCES IN VOLTAGE BETWEEN FACTORY AND CUSTOMERS PLANT MIGHT MAKE MINOR ADJUSTMENTS NECESSARY.

B. OIL

1. CHECK OIL DAILY. DO NOT ALLOW MACHINE TO RUN LOW. IF OIL PRESSURE GAUGE NEEDLE DOES NOT REMAIN ABOVE THE RED ZONE WHILE MACHINE IS RUNNING, STOP IMMEDIATELY.
2. AT OIL CHANGE INTERVALS, REMOVE BOTTOM COVER AND CLEAN, OR IF NECESSARY, REPLACE INTAKE FILTER. SEE PAGE 1.
3. REMOVE ACCUMULATIONS OF LINT AND DIRT FROM LOOPER AREA. IF PERMITTED TO REMAIN FOR LONG PERIODS OF TIME, THESE CAN SET UP A WICKING ACTION WHICH WILL ABSORB OIL FROM THE MACHINE.

C. THREAD BREAKAGE OR SKIPPING STITCHES

1. CHECK TO BE SURE NOTHING IS INTERFERING WITH THE FREE PASSAGE OF THE THREAD FROM THE CONE ALL THE WAY TO THE NEEDLE AND LOOPER.
2. CHECK TO SEE THAT BOTH NEEDLE AND LOOPER ARE THREADED PROPERLY. SEE DRAWING 2. IF EITHER ARE THREADED IMPROPERLY, IT COULD CAUSE THE NEEDLE THREAD TO BREAK. USE THE TWEEZERS SUPPLIED WITH THE MACHINE TO THREAD THE TOP (OR BACK) END OF LOOPER.
3. CHECK THE NEEDLE THREAD PULL-OFF. SEE PAGE 4. IF BAG IS DOUBLED OVER, ADD ABOUT 1/8".
4. CHECK TENSION OF BOTH THREADS. SEE PAGE 3.
5. REPLACE NEEDLE. SEE PAGE 3.
6. CHECK CONDITION OF LOOPER. IF IT IS ROUGH OR HAS SOME NICKS, REPLACE IT. SEE PAGE 5.
7. CHECK CONDITION OF THROAT PLATE. IF IT IS ROUGH OR HAS NICKS, REPLACE IT.

8. CHECK SHARPNESS OF FEED DOG. IF DULL, REPLACE IT.  
NOTE: ONLY THE OUTSIDE ROWS OF TEETH SHOULD BE SHARP. DO NOT SHARPEN CENTER TEETH.

D. FAILURE TO CHAIN OFF AFTER BAG IS SEWN

1. CHECK ITEMS LISTED UNDER THREAD BREAKAGE ABOVE.
2. CHECK PRESSER FOOT PRESSURE. IT SHOULD BE APPROXIMATELY 40 POUNDS. SEE PAGE 5.

E. UNEVEN STITCH LENGTH OR POOR FEEDING

CHECK SHARPNESS OF FEED DOG AND PRESSER FOOT PRESSURE.

F. EXCESSIVE NEEDLE BREAKAGE

1. OPERATOR MAY BE PULLING BAG THROUGH MACHINE.
2. SEWING MAY BE TOO CLOSE TO CONTENTS OF BAG.
3. CHECK ALIGNMENT OF NEEDLE SLOT IN PRESSER FOOT TO BE SURE NEEDLE DOES NOT RUB.
4. CHECK TO SEE THAT THE NEEDLE CHUCK IS PARALLEL WITH SIDE OF MACHINE.
5. CHECK SHARPNESS OF FEED DOG.
6. CHECK SYNCHRONIZATION.

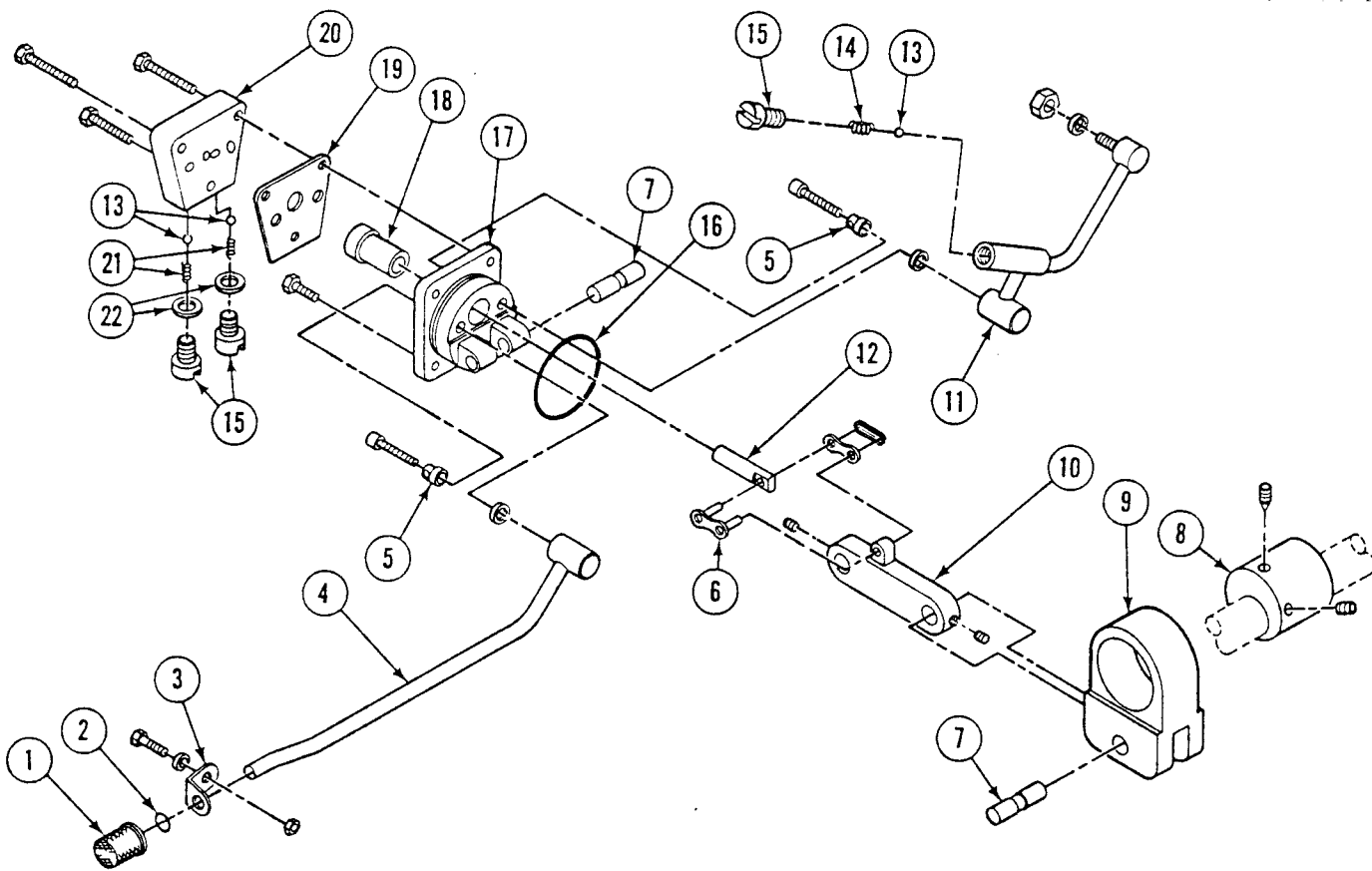

OIL PUMP & COUNTERWEIGHT ASSEMBLY			
ITEM NO.	PART NO.	DESCRIPTION	QTY.
1	A-10191	ASS'Y, FILTER - INTAKE.....	1
2	P-10192	RING, "O" - INTAKE FILTER.....	1
3	A-10204	RETAINER, TUBE - INTAKE.....	1
	B103212	SCREW, BINDING HD.....	1
	WN8	WASHER, NYLON.....	1
	NJ10	NUT.....	1
4	A-10105	ASS'Y, TUBE - INTAKE.....	1
	P-10107	RING, "O" - INTAKE TUBE.....	1
5	A-10178	INSERT, BODY - PUMP.....	2
	SC63278	SCREW, SOCKET HD CAP.....	2
6	P-10104	LINK, CONNECTING - PUMP DRIVE.....	1
7	A-10103	PIN, PIVOT - PUMP DRIVE.....	2
8	A-10061	ECCENTRIC, STROKE - PUMP.....	1
	SS142038	SCREW, SET.....	1
	SS142038CP	SCREW, SET - CONE POINT.....	1
9	A-10101	COUNTERWEIGHT & PUMP DRIVE.....	1
10	A-10102	LINK, CONTROL - PUMP DRIVE.....	1
	SS1032316	SCREW, SET.....	2
11	A-10106	ASS'Y, TUBE - PRESSURE.....	1
	NJ1420	NUT, HEX.....	1
	P-10107	RING, "O" - TUBE TERMINAL.....	2
12	A-10169	PISTON, PUMP.....	1
13	P-10051	BALL, VALVE.....	3
14	A-10130	SPRING, RELIEF - OIL PRESSURE.....	1
15	A-10053	PLUG, SPRING - VALVE.....	3
16	P-10084	RING, "O".....	1
17	B-10167	BODY, PUMP.....	1
	H103212	SCREW, HEX HD.....	2
18	A-10168	CYLINDER, PUMP.....	1
19	A-10049	GASKET, BLOCK - VALVE.....	1
20	B-10050	BLOCK, VALVE.....	1
	H1032114	SCREW, HEX HD (LONG).....	2
	H10321	SCREW, HEX HD (SHORT).....	1
21	A-10127	SPRING, BLOCK - VALVE.....	2
22	A-10052	SEAL, WASHER - VALVE PLUG.....	2

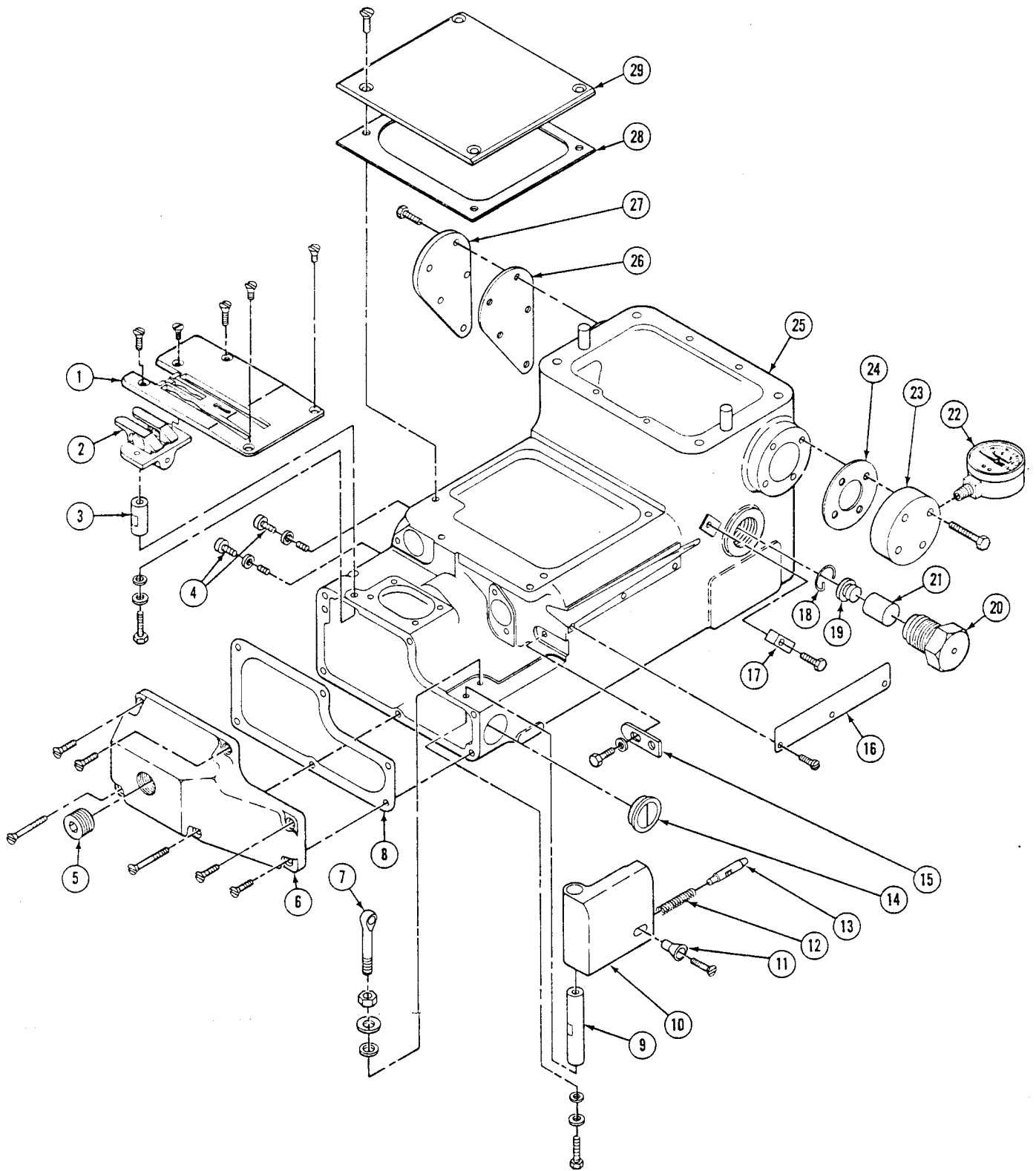

MAIN HOUSING			
ITEM NO.	PART NO.	DESCRIPTION	QTY.
1	B-10302	PLATE, THROAT - RAMP CUTTER (LONG STITCH)....	1
	B-10303	PLATE, THROAT - RAMP CUTTER.....	1
	F103258	SCREW, FLAT HD (LONG).....	2
	F103238	SCREW, FLAT HD (SHORT).....	3
2	B-10304	RAMP.....	1
	F103238	SCREW, FLAT HD.....	1
3	A-10015	POST, SHORT - THROAT PLATE.....	1
	H103212	SCREW, HEX HD.....	1
	WN8	WASHER - NYLON.....	1
	D208	WASHER.....	1
4	B103238	SCREW, BINDING HD.....	2
	WN8	WASHER.....	2
5	P-10111	PLUG, DRAIN - MAGNETIC.....	1
6	B-10022	COVER, BOTTOM.....	1
	F1032114	SCREW, FLAT HD (LONG).....	2
	F103258	SCREW, FLAT HD (SHORT).....	4
7	A-10170	PULL-OFF - LOOPER THREAD.....	1
	NH1420	NUT, HEX.....	1
	WF14	WASHER.....	1
	WN14	WASHER - NYLON.....	1
8	A-10093	GASKET, COVER - BOTTOM.....	1
9	A-10016	POST, LONG - THROAT PLATE.....	1
	H103212	SCREW, HEX HD.....	1
	WN8	WASHER - NYLON.....	1
	D208	WASHER.....	1
10	A-10005	DOOR, LOOPER.....	1
11	A-10021	KNOB, LATCH - LOOPER DOOR.....	1
	F63234	SCREW, FLAT HD.....	1
12	A-10019	SPRING, LATCH - LOOPER DOOR.....	1
13	A-10020	LATCH, DOOR - LOOPER.....	1
14	P-10112	WINDOW, OIL LEVEL.....	1
15	A-10097	PLATE, LATCH - LOOPER DOOR.....	1
	H103212	SCREW, HEX HD.....	1
	D208	WASHER.....	1
16	A-10098	COVER, GROOVE - THREAD.....	1
	B632316	SCREW, BINDING HD.....	3
17	A-10164	EYELET, THREAD - SHORT.....	1
	H103234	SCREW, HEX HD.....	1
18	A-10134	RING, SNAP - BREATHER BAFFLE RETAINER.....	1
19	A-10179	BAFFLE, PLUG - BREATHER.....	1
20	A-10116	ASS'Y, PLUG - BREATHER.....	1
21	A-10121	FILTER, PLUG - BREATHER.....	1
22	P-10227	GAUGE, OIL PRESSURE.....	1
23	P-10226	ADAPTER, GAUGE - OIL PRESSURE.....	1
	H10321	SCREW, HEX HD.....	4
24	A-10094	GASKET, MAIN SHAFT SEAL.....	1
25	D-10001	HOUSING, MAIN.....	1
26	A-10095	GASKET, COVER - MANIFOLD.....	1
27	A-10100	COVER, MANIFOLD.....	1
	H103212	SCREW, HEX HD.....	5
28	A-10092	GASKET, COVER - TOP.....	1
29	A-10014	PLATE, COVER - TOP.....	1
	F103238	SCREW, FLAT HD.....	4

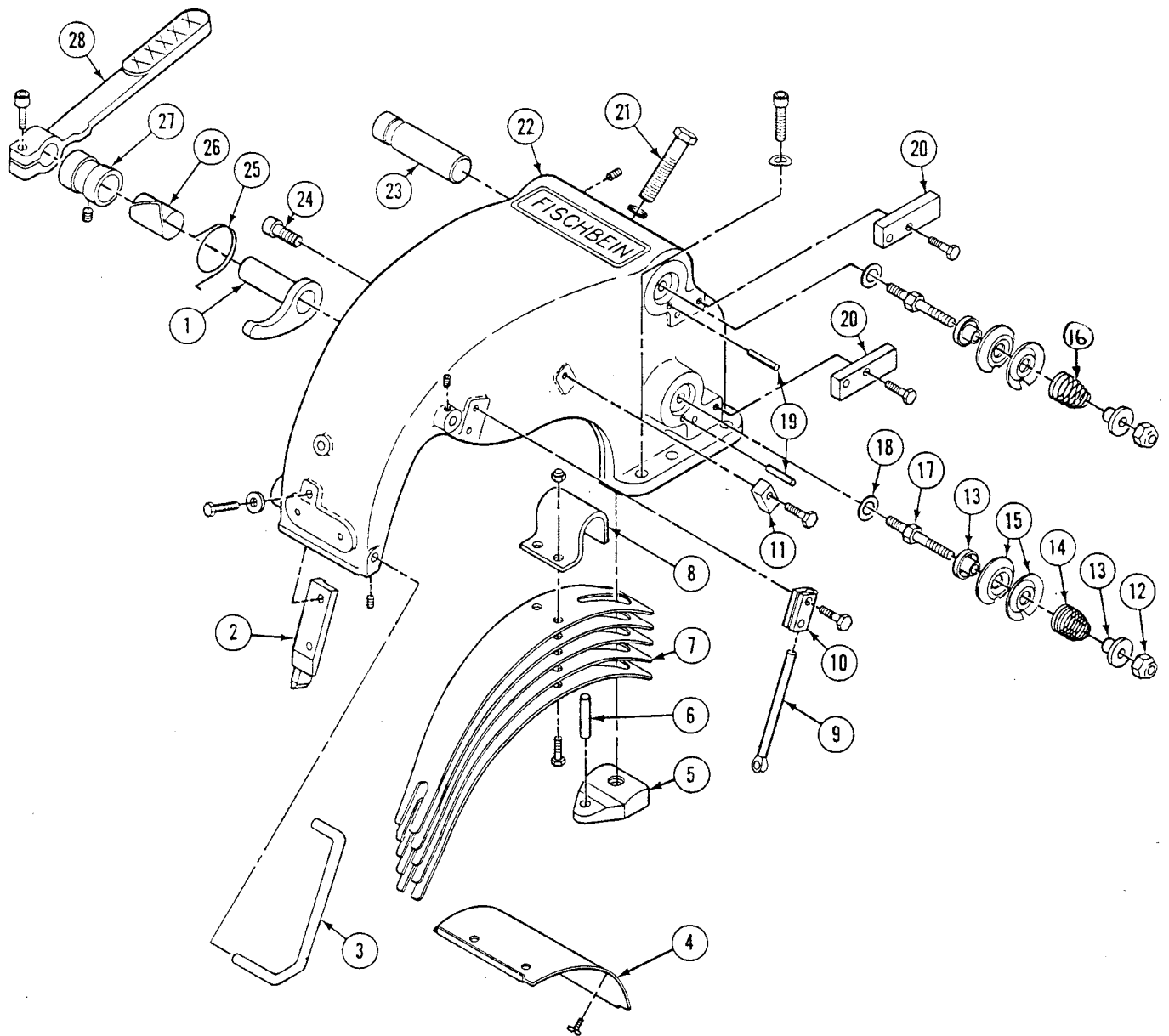

LEVERS HOUSING

ITEM NO.	PART NO.	DESCRIPTION	QTY.
1	A-10142	CAM, LIFTER - PRESSER FOOT.....	1
2	A-10161	GUIDE, LEVER - PRESSER FOOT.....	1
	H103278	SCREW, HEX HD.....	2
	WF10	WASHER.....	2
3	A-10188	GUARD, TENSION - NEEDLE.....	1
	SS1032516	SCREW, SET.....	2
4	B-10123	COVER, GUARD - LEVERS .....	1
	B103238	SCREW, BINDING HD.....	2
5	A-10146	PLATE, PRESSER FOOT SPRING - TAPPED.....	1
6	P-10013	PIN, ROLL.....	1
7	B-10145	SPRING, PRESSER FOOT.....	5
	H103234	SCREW, HEX HD.....	2
	1-178	NUT, LOCK .....	2
8	A-10144	CLAMP, SPRING - PRESSER FOOT.....	1
9	A-10171	PULL-OFF, NEEDLE THREAD.....	1
10	A-10172	CLAMP, NEEDLE THREAD PULL-OFF.....	1
	H103234	SCREW, HEX HD.....	2
11	A-10164	EYELET, THREAD - SHORT.....	1
	H103234	SCREW, HEX HD .....	1
12	NH1428L	NUT.....	2
13	A-10114	SLEEVE, TENSION.....	4
14	A-10008	SPRING, TENSION - LOOPER THREAD.....	1
15	A-10120	DISC, TENSION - LARGE.....	4
16	A-10007	SPRING, TENSION - NEEDLE THREAD.....	1
17	A-10115	STUD, TENSION.....	2
18	D-120	WASHER, LOCK.....	2
19	P-10010	PIN, RETAINING - TENSION DISC.....	2
20	A-10165	EYELET, THREAD - LONG.....	2
	H103234	SCREW, HEX HD.....	4
21	H3824134	SCREW, ADJUSTING.....	1
	WF38	WASHER.....	1
22	D-10002	HOUSING, LEVERS.....	1
	SC516181	SCREW, SOCKET HD CAP .....	4
	WS516	WASHER, SPRING.....	4
23	A-10143	SHAFT, SPRING - PRESSER FOOT.....	1
	SS142038	SCREW, SET .....	1
24	SC5161858	SCREW, STOP - LIFTER LEVER.....	1
25	A-10187	SPRING, LIFTER LEVER.....	1
26	A-10186	LINER, BUSHING - LIFTER LEVER.....	1
27	A-10139	BUSHING, LIFTER - PRESSER FOOT.....	1
	SS142014	SCREW, SET.....	1
28	B-10141	LEVER, LIFTER - PRESSER FOOT.....	1
	SC142034	SCREW, SOCKET HD CAP.....	1

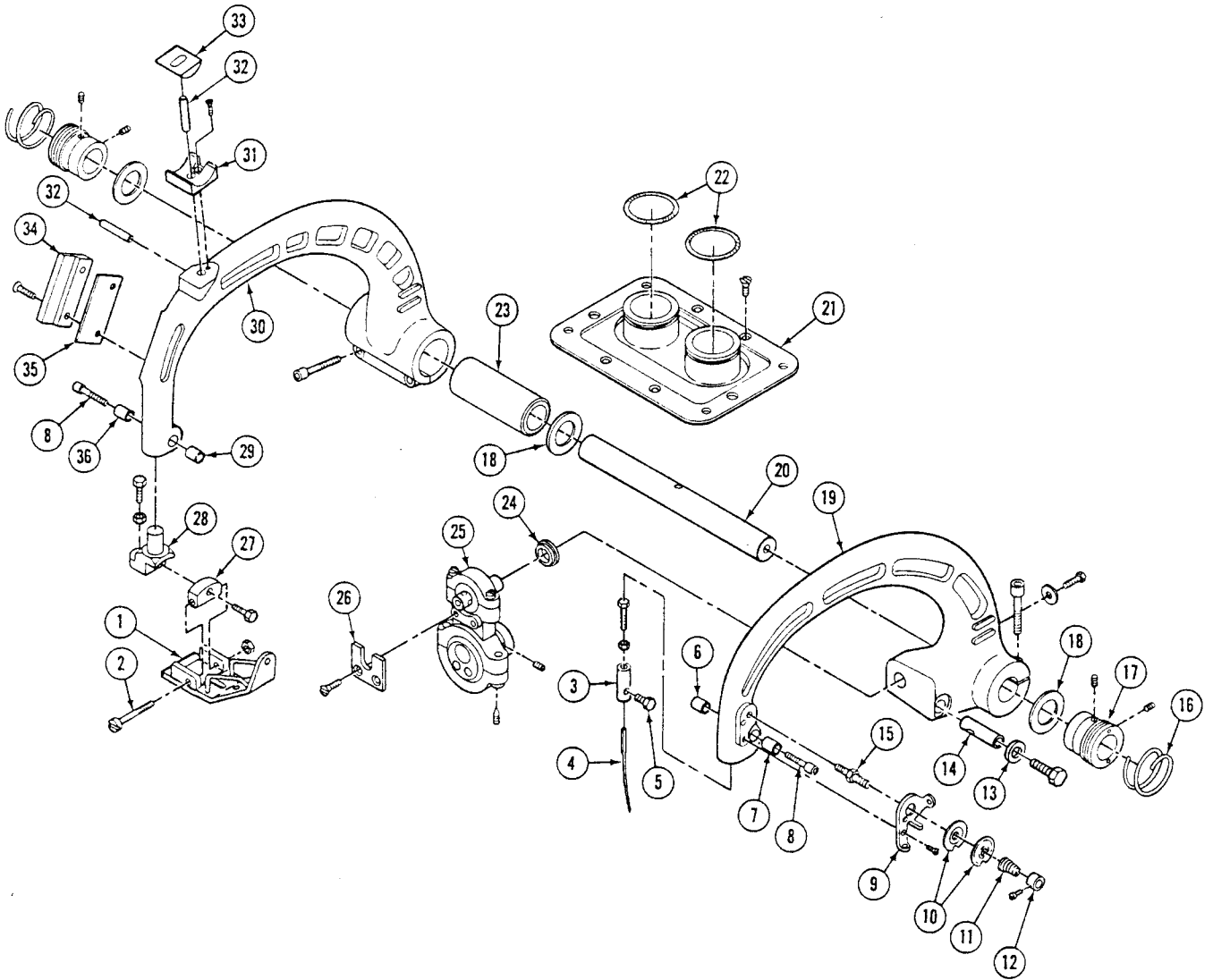



NEEDLE & PRESSER FOOT LEVER ASSEMBLIES

ITEM NO.	PART NO.	DESCRIPTION	QTY.
1	A-10185	PRESSER FOOT.....	1
2	A-10182	BOLT, HINGING - PRESSER FOOT.....	1
	NJ10	NUT.....	1
3	A-10031	CHUCK, NEEDLE.....	1
	H103234	SCREW, HEX HD.....	1
	NJ10	NUT, HEX HD.....	1
4	C-100-S	NEEDLE.....	1
5	A-10011	SCREW, CLAMP NEEDLE.....	1
6	A-10212	PLUG, CLAMP-TAPPED (NEEDLE LEVER).....	1
7	A-10211	PLUG, CLAMP-DRILLED (NEEDLE LEVER).....	1
8	SC63234	SCREW, SOCKET HD. CAP.....	1
9	A-10166	GUIDE, THREAD - NEEDLE LEVER.....	1
	F54038	SCREW, FLAT HD.....	2
10	A-10119	DISC, TENSION - SMALL.....	2
11	A-10009	SPRING, TENSION - NEEDLE LEVER.....	1
12	A-10181	COLLAR, TENSION - NEEDLE LEVER.....	1
	B632316	SCREW, BINDING HD.....	1
13	A-10231	WASHER, HEAVY - NEEDLE LEVER.....	1
	H103212	SCREW, HEX HD.....	1
14	A-10232	ROD, CLAMP - NEEDLE LEVER.....	1
15	A-10113	STUD, TENSION - NEEDLE LEVER.....	1
16	A-10023	INSERT, THREAD - LEVERS SHAFT BUSHING.....	2
17	A-10025	BUSHING, SHAFT LEVERS.....	2
	SS1032316	SCREW, SET (SHORT).....	2
	SS103238	SCREW, SET (LONG).....	2
18	T3129	WASHER, THRUST.....	3
19	C-10003	LEVER, NEEDLE.....	1
	SC1420114	SCREW, SOCKET HD. CAP.....	2
20	A-10026	SHAFT, LEVERS.....	1
21	B-10137	SEAL, LEVERS.....	1
	F103238	SCREW, FLAT HD.....	4
22	A-10128	SPRING, GARTER - LEVER SEAL.....	2
23	A-10028	BUSHING, LEVER - PRESSER FOOT.....	1
24	A-10159	SPACER, STUD - BALL.....	1
25	B-10047	ROD, CONNECTING - NEEDLE DRIVE.....	1
	SS142038CP	SCREW, SET - CONE POINT.....	1
	SS142014	SCREW, SET.....	1
	H103238	SCREW, HEX HD.....	1
	WS10	WASHER, SPRING.....	1
26	A-10048	RETAINER, ROD - CONNECTING.....	1
	F103238	SCREW, FLAT HD.....	2
27	A-10156	BLOCK, HINGE - PRESSER FOOT.....	1
	H103234	SCREW, HEX HD.....	1
28	A-10155	SHANK, PRESSER FOOT.....	1
	H103234	SCREW, HEX HD.....	1
	NJ10	NUT, HEX.....	1
29	A-10214	PLUG, CLAMP - TAPPED (PRESSER FOOT).....	1
30	C-10004	LEVER, PRESSER FOOT.....	1
	SC1420114	SCREW, SOCKET HD. CAP.....	2
31	A-10189	CRADLE, PAD - PRESSER FOOT SPRING.....	1
	F63212	SCREW, FLAT HD.....	1
32	P10193	PIN, ROLL.....	2
33	A-10190	PAD, SPRING - PRESSER FOOT.....	1
34	A-10163	CLAMP, BEARING - SHEET.....	1
	F103258	SCREW, FLAT HD.....	2
35	A-10162	SHEET, BEARING - PRESSER FOOT LEVER GUIDE....	1
36	A-10213	PLUG, CLAMP - DRILLED (PRESSER FOOT).....	1

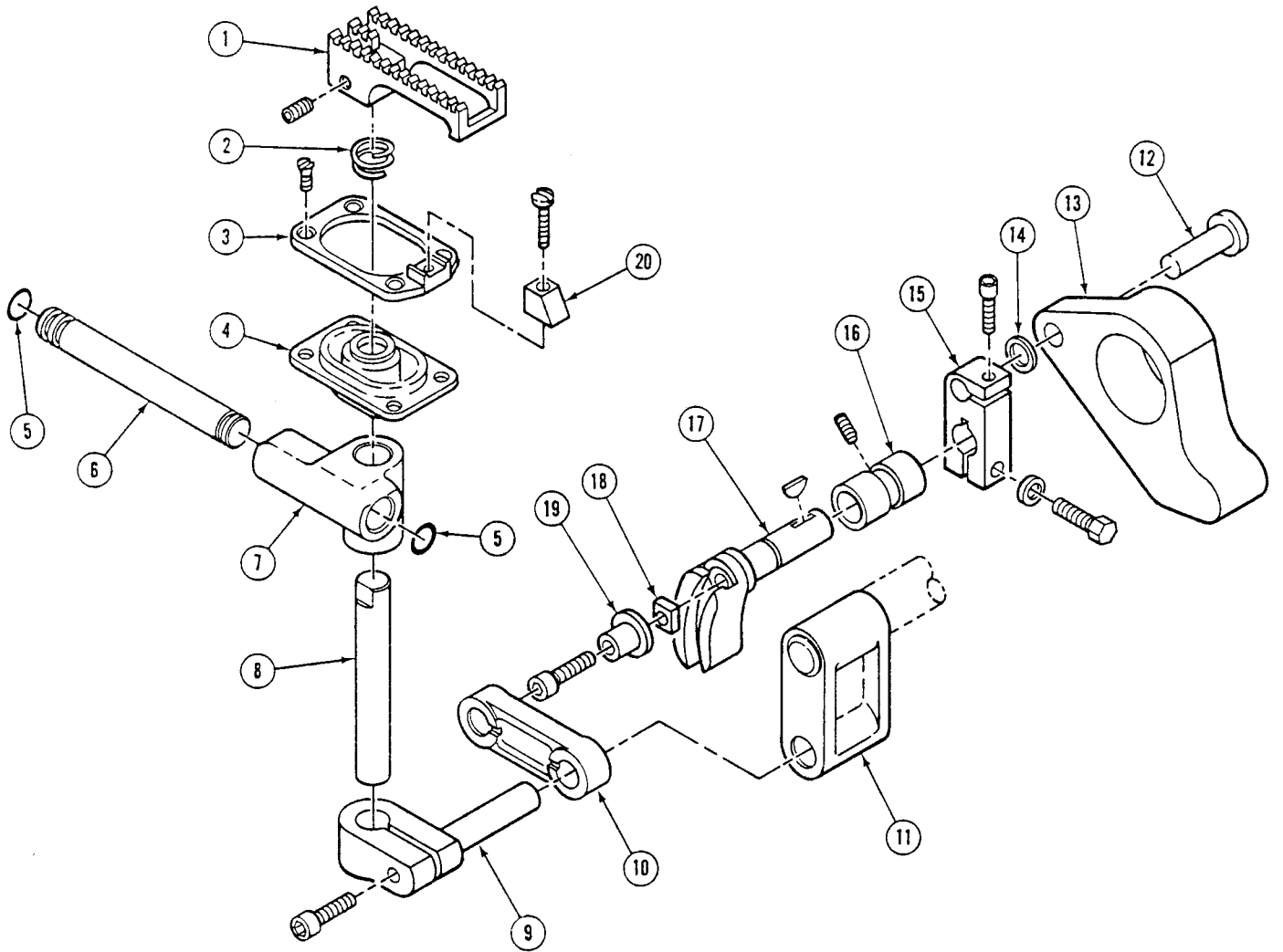

FEED ASSEMBLY			
ITEM NO.	PART NO.	DESCRIPTION	QTY.
1	A-10078	DOG, FEED.....	1
	A-10079	DOG, FEED (LONG STITCH).....	1
	SS1032516	SCREW, SET.....	1
2	A-10124	RING, GARTER - FEED DOG SEAL.....	1
3	A-10177	HOLDER, GUARD - NEEDLE.....	1
	F103238	SCREW, FLAT HD.....	4
4	B-10077	SEAL, DOG - FEED.....	1
5	P-10075	RING, "O".....	2
6	A-10074	ROD, SLIDE - FEED.....	1
7	A-10073	SLIDE, FEED.....	1
8	A-10072	ROD, CARRIER - FEED DOG.....	1
9	A-10070	CLAMP, ROD - FEED DOG CARRIER.....	1
	SC142078	SCREW, SOCKET HD.....	1
10	A-10069	LINK, STROKE - FEED.....	1
11	A-10071	LINK, LIFT - FEED.....	1
12	A-10064	PIN, ROD - FEED STROKE CONNECTING.....	1
13	A-10062	ROD, CONNECTING - PRIMARY FEED STROKE.....	1
14	A-10215	WASHER, THRUST.....	1
15	A-10063	LEVER, PIN - FEED ROCKER.....	1
	SC54012	SCREW, SOCKET HD. CAP.....	1
	H103258	SCREW, HEX HD.....	1
	D208	WASHER.....	1
16	A-10109	BUSHING, SHAFT - FEED ROCKER.....	1
	SS1032516	SCREW, SET.....	1
17	A-10066	LEVER, SLOTTED - FEED ROCKER.....	1
	B1035	KEY.....	1
18	A-10067	NUT, PIVOT - FEED STROKE ADJUSTING.....	1
	SC142878	SCREW, SOCKET HD. CAP.....	1
19	A-10068	PIVOT, ADJUSTING - FEED STROKE.....	1
20	A-10174	GUARD, NEEDLE.....	1
	P540916	SCREW, PAN HD.....	1

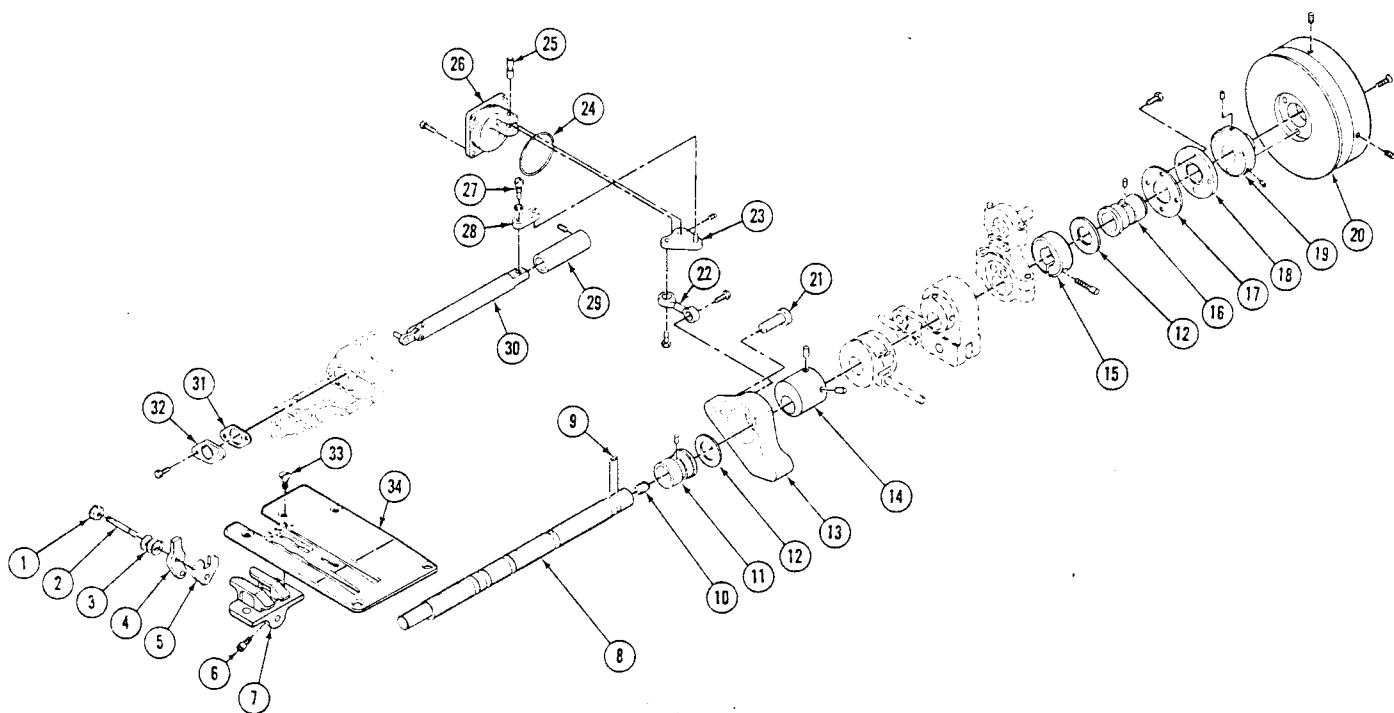

MAIN SHAFT & KNIFE ASSEMBLY			
ITEM NO.	PART NO.	DESCRIPTION	QTY.
1	1-178	NUT, LOCK.....	1
2	A-10305	STUD, PIVOT.....	1
3	B-2043	WASHER, SPRING.....	3
4	A-10307	KNIFE, MOVING.....	1
5	A-10306	KNIFE, BED.....	1
6	SC54014	SCREW, SET.....	1
7	B-10304	RAMP.....	1
8	C-10045	SHAFT, MAIN.....	1
9	B-1035	KEY.....	1
10	P-10125	PLUG, PIPE - MAIN SHAFT.....	1
11	A-10044	BUSHING, MAIN SHAFT - NEEDLE END.....	1
	SS1032516	SCREW, SET.....	1
12	T-3129	WASHER, THRUST.....	2
13	A-10062	ROD, CONNECTING - PRIMARY FEED STROKE.....	1
14	A-10061	ECCENTRIC, STROKE - FEED.....	1
	SS142038	SCREW, SET.....	1
	SS142038-CP	SCREW, SET - CONE POINT.....	1
15	A-10158	COLLAR, LOCK - MAIN SHAFT.....	1
	SC103258	SCREW, SOCKET HD. CAP.....	1
16	A-10043	BUSHING, MAIN SHAFT - DRIVE END.....	1
	SS1032516	SCREW, SET.....	1
17	A-10094	GASKET, MAIN SHAFT SEAL.....	1
18	A-10035	ASSY, SEAL - MAIN SHAFT.....	1
	H103212	SCREW, HEX HD.....	4
19	A-10038	HUB, PULLEY.....	1
	SS142038	SCREW, SET.....	2
20	A-10199	PULLEY, ADJUSTABLE.....	1
	SS142038	SCREW, SET.....	2
	F103258	SCREW, FLAT HD.....	3
21	A-10064	PIN, ROD - FEED STROKE CONNECTING.....	1
22	A-10080	ASSY, CONNECTING ROD - KNIFE.....	1
	H103212	SCREW, HEX HD.....	1
	H103258	SCREW, HEX HD.....	1
23	A-10082	CRANK, BELT - KNIFE.....	1
	SS540316	SCREW SET.....	1
24	P-10084	RING, "O".....	1
25	A-10083	SHAFT, BELL CRANK - KNIFE.....	1
26	B-10085	BRACKET, PIVOT - KNIFE.....	1
	H103212	SCREW, HEX HD.....	4
27	A-10087	SCREW, PIVOT - KNIFE.....	1
	D120	WASHER, LOCK.....	1
28	A-10086	LINK, KNIFE.....	1
29	A-10056	BUSHING, SHAFT - KNIFE.....	1
	SS1032516	SCREW, SET.....	1
30	A-10311	ASSY, SHAFT & LINK.....	1
31	A-10058	GASKET, SEAL - KNIFE SHAFT.....	1
32	A-10076	ASSY, SEAL - KNIFE SHAFT.....	1
	H103212	SCREW, HEX HD.....	2
33	F103238	SCREW, FLAT HD.....	1
34	B-10303	PLATE, THROAT - RAMP CUTTER.....	1
	B-10302	PLATE, THROAT- RAMP CUTTER (LONG STITCH).....	1

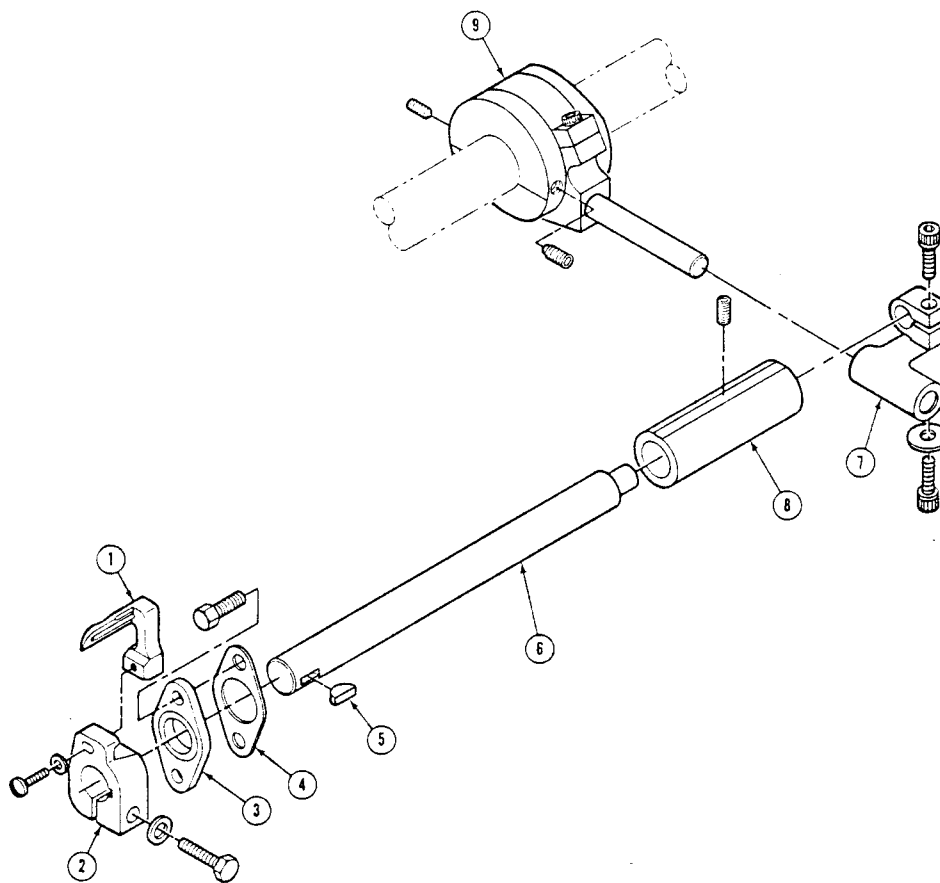

LOOPER ASSEMBLY			
ITEM NO.	PART NO.	DESCRIPTION	QTY.
1	C-10060	LOOPER (TWO THREAD).....	1
	C-10208	LOOPER (SINGLE THREAD).....	1
	P540916	SCREW, PAN HD.....	1
	WF5	WASHER.....	1
2	A-10059	HOLDER, LOOPER.....	1
	H103234	SCREW, HEX HD.....	1
	D208	WASHER.....	1
3	A-10076	ASS'Y SEAL - LOOPER SHAFT.....	1
	H103212	SCREW, HEX HD.....	2
4	A-10058	GASKET, SEAL - LOOPER SHAFT.....	1
5	B1035	KEY.....	1
6	A-10055	SHAFT, LOOPER.....	1
7	A-10173	ASS'Y, PIVOT - LOOPER.....	1
	SC103212	SCREW, SOCKET HD CAP.....	2
	WF10S	WASHER.....	1
8	A-10056	BUSHING, SHAFT - LOOPER.....	1
	SS1032516	SCREW, SET.....	1
9	A-10150	ASS'Y CAM - LOOPER.....	1
	SS103258-CPL	SCREW, SET - CONE POINT.....	1
	SS103212L	SCREW, SET.....	1

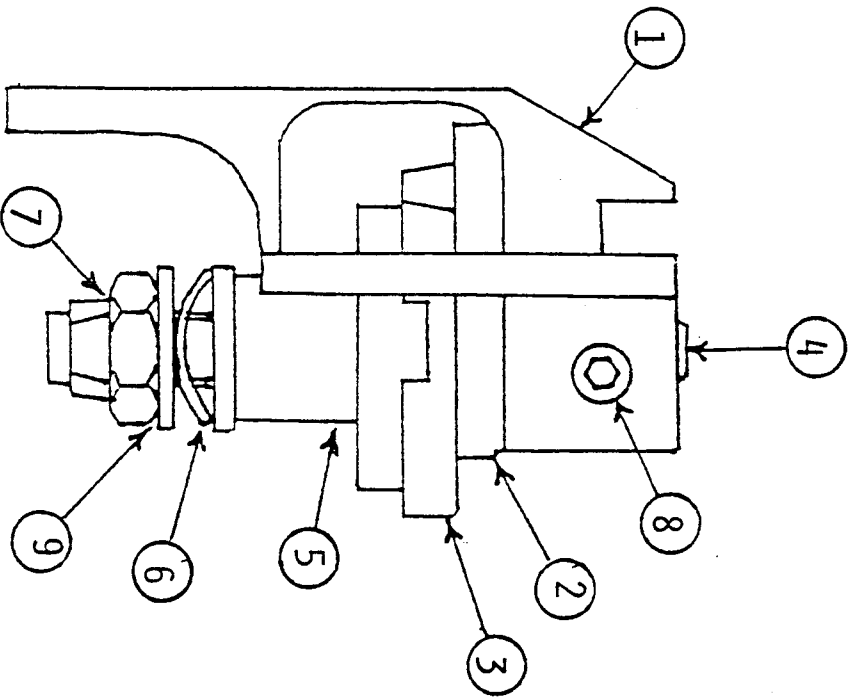

ITEM	QUAN	PART NO.	DESCRIPTION
9	2	WS10	WASHER, SPRING - #10
8	1	SC54014	SCREW, SOC. CAP. #5-40 N.C. X 1/4
7	1	1-178	NUT, LOCK - #10-32 N.F.
6	1	10337	WASHER, BOWER SPRING
5	1	10336	BUSHING, KNIFE - THRUST
4	1	10335	STUD, PIVOT - LONG
3	1	10307	KNIFE, MOVING
2	1	10306	KNIFE, BED
1	1	10304	RAMP, LONG

**DAVE FISCHBEIN MFG. CO.**  
 2700-30TH AVE. SO. MINNEAPOLIS, MINN. 55406

NAME ASSY., RAMP CUTTER - MODIFIED  
 MATERIAL B.O.M.

TOLERANCE UNLESS SPECIFIED		FINISH	SCALE 2X
FRACTIONAL	± 1/64	DRN B	
DECIMAL	± .005	DATE 6-26-81	10334
ANGUL	± 30 MIN.	CK'D DATE	







"SHORT STITCHES" - #4

by Carl Johnson  
April 1, 1980

THE GAUGE

A NECESSARY TOOL FOR 10M ADJUSTMENTS. THE FOLLOWING ITEMS WILL SERVE AS A PERMANENT REFERENCE FOR THE USE OF THE GAUGE:

The gauge (our Part #A10230) has three important dimensions and three separate functions.

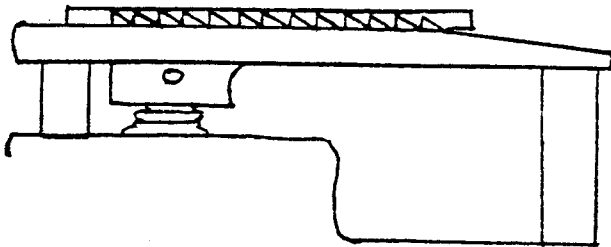

1. The gauge thickness,  $1/16$ " , is used to check the height of the feed dog above the throat plate at the top of the stroke. The measurement is made with the presser foot on the machine and no thread between the foot and the feed dog. The gauge should fit between the plate and presser foot. If it doesn't fit the feed dog is worn and needs to be replaced or adjusted higher.

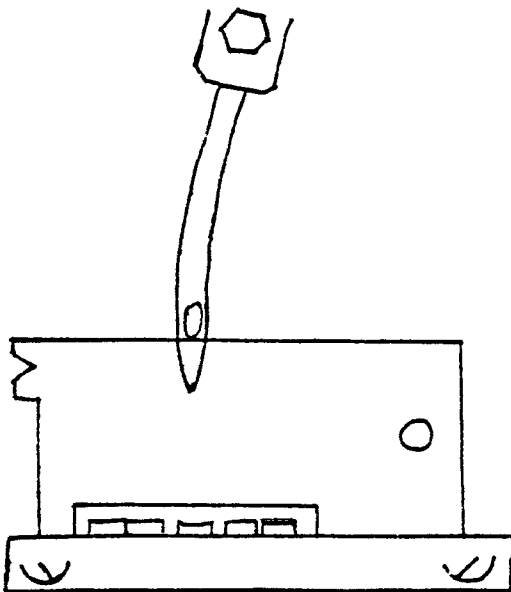

2. By standing the gauge on edge we check the height of the needle stroke. The throat plate must be on the machine for this check because the measurement is made from the throat plate to the bottom of the eye of the needle. This dimension,  $1 \frac{1}{8}$ " , is a very critical adjustment. Be sure the needle is in the chuck all the way. The cut away portion  $1/4$ " x  $1 \frac{1}{4}$ " allows us to make this check when the foot and feed dog are on the machine. The needle and feed dog will be at the top of the stroke at this point.

**DAVE FISCHBEIN COMPANY**

A Division of AXIA — a family of leading-edge companies

2700 30th Avenue South, Minneapolis, Minnesota 55406, U.S.A. • Phone: 612/721-4806 • Telex: 29-0963 • Cable Address: FISCHBEIN



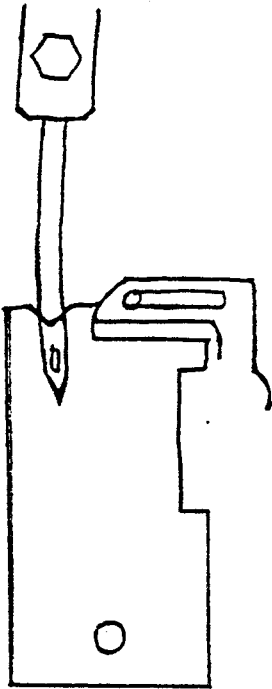

3. The third use of the gauge is to check the stroke or timing of the looper. With the looper to the right of the needle as far as it will travel or with the looper retracted into the machine as far as it will go, measure from the center of the needle to the tip of the looper. The moving parts should be well oiled inside the machine at this point to reduce free travel or excessive movement of the looper. The small V in the gauge is now placed on the needle. The looper can be adjusted so the gauge clears the looper and that the looper is right up to the gauge.

4. Other uses: The gauge is exactly 3" long at the longest point. This can be used as a gauge to measure stitch length. The gauge is also a good straight edge to check the rotation of the needle chuck for being parallel with the machine by placing it on the needle clamping screw. When held firmly on the screw it should seek a straight line parallel with machine.

P.S. The hole in the gauge is merely to hang the gauge when not in use.